

## BUILDING PRODUCTS LISTING PROGRAM

**Class:** Mineral-fiber Fireproofing Materials – Grease Ducts

**Customer:** CL4 Inc.  
**Location:** Kemptville, Ontario Canada  
**Website:** <https://www.cl4fire.com>  
**Listing No.** F405-1-4  
**Effective Date:** January 6, 2012  
**Last Revised:** March 31, 2022  
**Expires:** N/A

**Products:** CL4Fire Blue Label Mineral-fiber Fireproofing Insulation  
 CL4Fire Red Label & CL4Fire Code 96 Mineral-fiber Fireproofing Insulation

**Standard(s):** ASTM E2336 “Standard Test Methods for Fire Resistive Grease Duct Enclosure Systems”.  
 CAN/ULC S144 “Standard Method of Fire Resistance Test – Grease Duct Assemblies”.  
 ASTM E136 “Standard Test Method for Behavior of Materials in a Vertical Tube Furnace at 750°C”.  
 CAN/ULC S102 “Standard Method of Test for Surface Burning Characteristics of building Materials and Assemblies.”

**Model/Ratings:** CL4Fire products have surface burning characteristics determined in accordance with CAN/ULC S102 as outlined below.

Product	Nominal Density lbs/ft <sup>3</sup> (kg/m <sup>3</sup> )	Flame Spread Index	Smoke Developed Index
CL4Fire Blue Label	8 (128)	10	10
CL4Fire Red Label	6 (96)		
CL4Fire Code 96*	6 (96)		

Note: CL4Fire Code 96 follows all the same installation requirements as CL4Fire Red Label but has an integral wire mesh per NFPA 96 4.2.3.2 for added support.

CL4Fire Blue Label, CL4Fire Red Label and CL4Fire Code 96 are classified as non-combustible per ASTM E136.

CL4Fire Grease Duct Ratings for Use in ASTM E2336 / CAN/ULC S144 Required Assemblies

**Limitations:**

Product	Installation	Minimum Installed Thickness inches (mm)	Nominal Density lbs/ft <sup>3</sup> (kg/m <sup>3</sup> )	Fire Rating Achieved Hours
CL4Fire Blue Label	2 Layers 1 1/2" (38mm) Compressed Butt Joints or Overlap Minimum 3 inches (76 mm) at Seams.	3" (76mm)	8 (128mm)	2
	1 Layer 3 inch (76 mm) Compressed Butt Joints or Overlap Minimum 3 inches (76 mm) at Seams.	3" (76mm)	8 (128)	2
CL4Fire Red Label or CL4Fire Code 96	2 Layers 1 1/2" (38mm) Compressed Butt Joints or Overlap Minimum 3 inches (76 mm) at Seams.	3" (76mm)	6 (96)	2
	1 Layer 3 inch (76 mm) Compressed Butt Joints or Overlap Minimum 3 inches (76 mm) at Seams.	3" (76mm)	6 (96)	2

CL4Fire is limited for use to Grease ducts of the following:

- Maximum Duct Size: 1296 in<sup>2</sup> (8361 cm<sup>2</sup>)
- Maximum Width dimension of 92 cm (36 in) H x 92 cm (36 in) W. or
- Maximum Height dimension of 122 cm (48 in) H x 68 cm (27 in) W.
- Minimum duct gauge of 16 gauge (1.6 mm).
- Ducting is limited to rectangular, square or circular cross-section.
- Ducting is to conform to Sheet Metal and Air Conditioning Contractors' National Association (SMACNA) requirements.
- When used CL4Fire Code 96 should only be used in the outer wrap layer.

Product is to be installed per this listing F405-1-4

**Installation:**

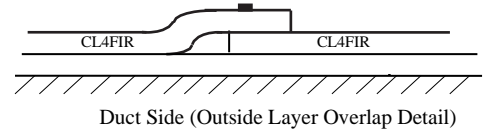
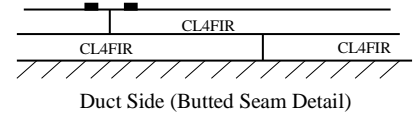
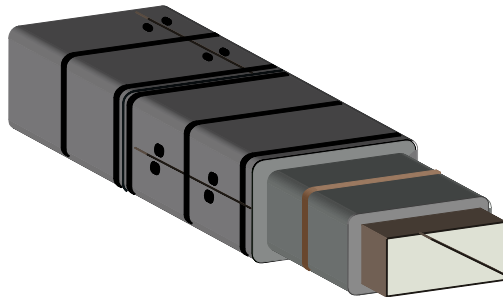

**Product: CL4FIRE 6 pcf. density, 2-layers of of 38mm (1 1/2") for an overall thickness of 76mm (3")**

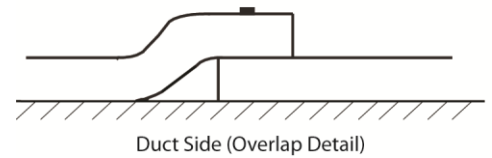
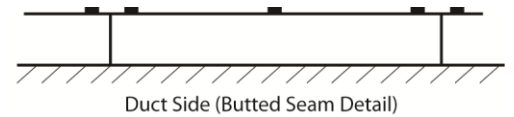
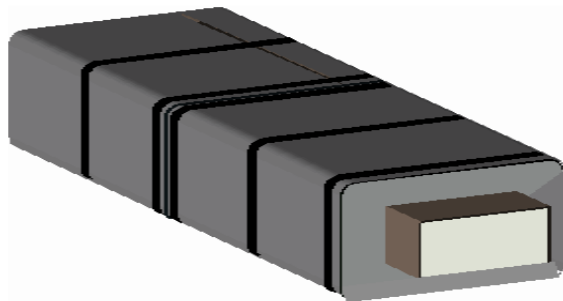

**Product: CL4FIRE 6 pcf. density, 1-layer of of 76mm (3") for an overall thickness of 76mm (3")**

**Product Assembly:**

Minimum 16 ga. Rectangular, Square or Round Steel Duct Complying with NFPA-96 requirements. Maximum 9663 sq. cm. (1296 sq. inch) duct with maximum single dimension of 1219mm (48")

## Support Rods & Cradles

Hanging supports must be installed per SMACNA guidelines with the following:

- Minimum 10mm (3/8") steel threaded rod with either of the following:
- Steel angle - 51mm x 51mm x 5mm (2" x 2" x 3/16") or Unistrut P2000 channel - 51mm x 5mm (2" x 3/16")
- Support rods to be anchored to concrete using pass thru method with a nut & washer on the top of the concrete slab, or by using suitable carbon or stainless steel masonry anchors penetrating a minimum 50mm (2") depth into the concrete slab.
- No additional protection is required for hanger systems

NOTE: If desired, it is acceptable to encase the cradle support assembly along with the duct within the \*CL4FIRE insulation (i.e.: cocoon wrap) during the installation. A slit is allowed in the duct wrap to position wrap around the threaded rod. Slit must be repaired and sealed using a minimum depth of 6mm sealant with a bead also placed around the circumference of the support rod.

## Standard Banding Fastening Method

- All cut ends of insulation to be repaired with aluminum tape
- Seams installed either by snugly fitting the seams together or by sealing any maximum 1/4" wide voids in the insulation seams with minimum of 1/2" depth of sealant. Alternately, seams on outside layer can be installed using 3" overlaps if desired.
- Pinning is required on the underside of CL4FIRE exposed ductwork joints for square or rectangular ducts 24" or larger. Pins are required within 1 1/2" from both sides of CL4FIRE longitudinal seam.
- Additional pins may be added to increase the integrity of the installation.
- 1/2" wide banding to be installed within 1 1/2" on both sides of a circumferential butted seam or centred on an overlapped seam. Banding to be stainless steel for up to a 2-hour fire rating or carbon steel for up to a 1- hour fire rating. Banding to be spaced a maximum of 12" apart.
- Center pins between steel banding with a 12" maximum distance between pins on the bottom of the ductwork and maximum of 12" between the side of the duct and the first row of pins. Note: Maximum 18" space is allowed between the edge of the duct and the first row of pins when not located on the bottom side of a horizontal duct.

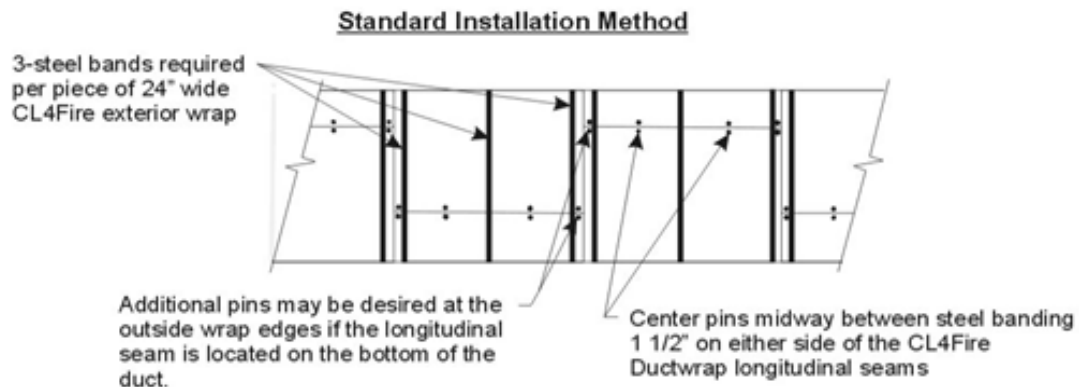

### Detail when longitudinal seam located on bottom of duct:

- 3" long x 1/8" copper coated steel insulation pins or Cup-Head Weldpins® required to be stud welded on bottom side of a horizontal duct. Pins are to be located a maximum 8" from edge of duct and on maximum 12" centers in 2 rows per 24" wide CL4FIRE installed section. Pins are centered between banding on each individual wrap section – See standard installation method pinning detail).

Note: No pins are required between the circumference seaming bands other than at the longitudinal joint. Additional pins may be installed to enhance the integrity of the CL4Fire duct wrap installation.

- CL4FIRE insulation to be impaled on pins and held in place with speed clips.
- Alternatively, ductwrap may be installed prior to pinning with Cup-Head Weldpins®.
- CL4FIRE ductwrap is held in place by banding the insulation around the duct approx. 1½" on both sides of the seam and in the center of the CL4FIRE wrap layer.
- No aluminum tape is required on seams, but it may be used for cosmetic reasons if desired.

Note: When encountering ductwork flanges using the butt seam and collar method it is not required to have the base layer of CL4FIRE insulation cover the top of the flange. It is only required that ductwork flange locations have the base layer of CL4FIRE insulation snugly butted against both sides of the flange and the 152mm wide CL4FIRE collar installed over the flange.

### 4-Sided Pinning Only Method

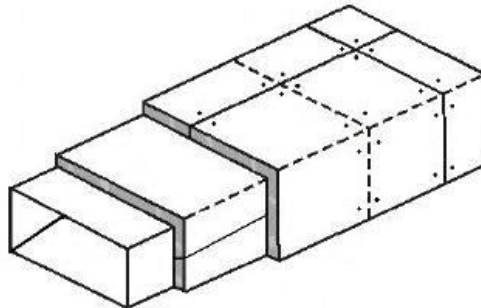

- All cut ends of insulation to be repaired with aluminum tape.
- Seams are installed snugly fitted or by sealing any max. ¼" wide voids in the seams with a minimum of ½" depth of the approved sealants (refer to the approved sealants Section).
- 3" long x 1/8" copper coated steel insulation pins or Cup-Head Weldpins®
- Pins are required on all sides of duct at max. 12" centers – max. 6" pin-free space from edge of ductwork is allowed.
- Install Cup-Head Weldpins® on both sides of the CL4FIRE ductwrap seam. Cup-Head Weldpins® must be located 3" apart (1½" on either side of the CL4FIRE ductwrap seams).
- Longitudinal seams of the outside layer of wrap material require CL4FIRE Ductwrap Pinning Only pinning at max 12" centers and max. 2" from each edge the ductwrap material.
- No aluminum tape is required on seams, but it may be used for cosmetic reasons if desired.

### Gypsum Shaft Transition (if required)

Should a transition be required from a gypsum shaft system to a CL4FIRE Fire Protection Thermal Insulation installation the annular space around the duct and the shaft must be filled with a minimum of 102mm (4") depth of CL4FIRE insulation and topped with a 6mm (1/4") depth of sealant flush with the surface of the gypsum.

### Approved Sealants:

- 3M Fire Barrier 1000 Silicone
- AD Fire Barrier Silicone
- Passive Fire Protection Partners 4800DW Sealant
- STi SIL300 Silicone Firestop Sealant
- STi SpecSeal® Series SSS Latex Intumescent Sealant
- STi SpecSeal® Series LCI Intumescent Sealant

Note: Equivalent sealants are acceptable, if they are tested and listed to CAN/ULC S115, ASTM E814-02 and UL1479

### CL4FIRE Ductwrap '2 or 3' Sided installation: Pinning Only Method

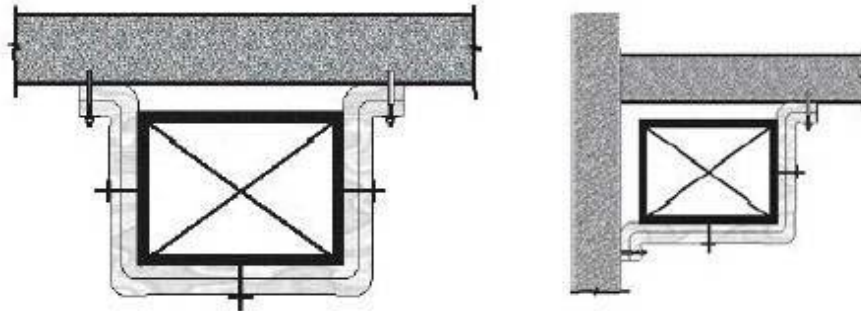

#### Installation

- Requires the CL4FIRE ductwrap insulation to be installed in accordance with the instructions shown in 'Pinning Only' Method
- Duct to be located a maximum of 4" from the floor or wall assembly.

#### Fastening

- Install Pinning only pins (or alternatively pin both sides of seam as outlined in CL4FIRE 'Pinning Only' Method) on exposed sides of duct and install CL4FIRE insulation using instructions shown in 'Pinning Only' Method.
- Overlap both layers of CL4FIRE ductwrap insulation over concrete by minimum of 3" and fasten using min 1 1/4" OD fender washers over a minimum 1/4" diameter steel concrete anchor inserted a minimum of 1 1/2" into concrete slab spaced a maximum of 8" apart.

### CL4FIRE Ductwrap '2 or 3' Sided installation: Banding Method

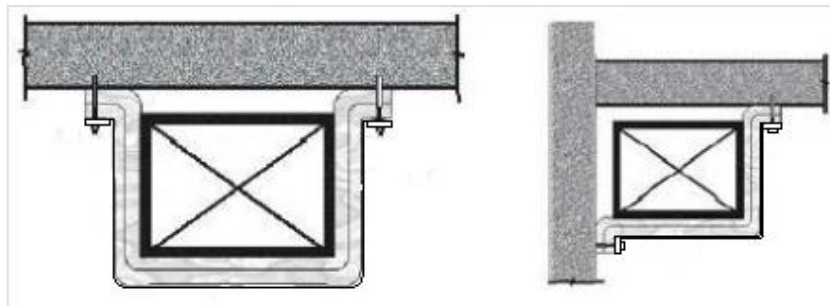

#### Installation

- Requires the CL4FIRE ductwrap insulation to be installed in accordance with the instructions shown in 'Standard Banding' Method
- Duct to be located a maximum of 4" from the floor or wall assembly.

D

#### Fastening

- Install pins on exposed sides of duct (if required) and install CL4FIRE insulation using instructions shown in 'CL4FIRE 'Standard Banding' Method.
- Overlap CL4FIRE insulation over the concrete by a minimum of 3".
- Anchor with a continuous length of min. 3/16" x 1 1/2" wide steel flat bar over flared ends of the wrap material and fasten using min. 1 1/4" OD fender washers over a minimum 1/4" diameter steel concrete anchors inserted a minimum of 1 1/2" into the concrete slab spaced a maximum of 8" apart.
- Banding to be installed over the wrapped duct with ends looped around the steel flat bars, tightened, and clipped as required.
- CL4FIRE fire protection thermal insulation is to be installed essentially to the requirements of CL4FIRE banding method.

#### **Grease Duct Insulation System**

The following CL4FIRE™ grease duct fire protection thermal insulation systems met the requirements of the CAN/ULC S144 and ASTM E2336 Standards:

- Two-layer of **CL4FIRE™ 'Blue' Label – 8 PCF - 3" Overall Thickness**
  - System Design Number: F405-2B3-GD
- Two-layer of **CL4FIRE™ 'Code 96 or Red' Label – 6 PCF - 3" Overall Thickness**
  - { System Design Number: F405-2R3-GD
- One-layer of **CL4FIRE™ 'Blue' Label – 8 PCF - 3" Overall Thickness**
  - System Design Number: F405-1B3-GD
- One-layer of **CL4FIRE™ 'Code 96 or Red' Label – 6 PCF - 3" Overall Thickness**
  - System Design Number: F405-1R3-GD

The steel duct shall be wrapped with any of the above noted grease duct wrap systems installed in accordance with the manufacturer's installation instructions. Product can be fastened with either CL4FIRE™ Standard or Pinned Only fastening method (shown above). All cut edges and ends shall be sealed with 76 mm (3") wide pressure sensitive aluminum foil tape.

Note: When encountering ductwork flanges using the butt seam and collar method it is not required to have the base layer of CL4FIRE insulation cover the top of the flange. It is only required that ductwork flange locations have the base layer of CL4FIRE insulation snugly butted against both sides of the flange and the 152mm wide CL4FIRE collar installed over the flange.



## CL4FIRE Ductwork Access Opening Detail

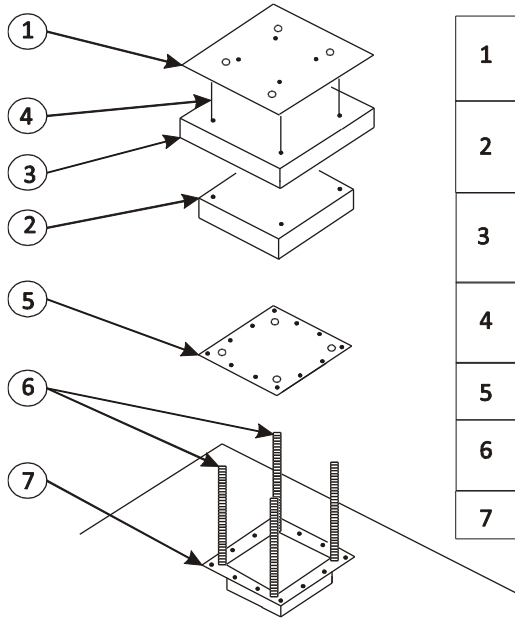

1	Galvanized steel cover plate fastened to (4) threaded rods with butterfly nuts & washers
2	CL4-Fire Ductwrap Insulation sized to match access cover plate (foil tape all open edges)
3	CL4-Fire Ductwrap Insulation sized to overlap item #2 by minimum 1" all around (foil tape all open edges)
4	Insulation pins welded to item #1 With insulation retaining speed clips
5	Access Opening Cover Plate
6	(4) Threaded rods welded to access opening flange
7	Flanged Access Opening

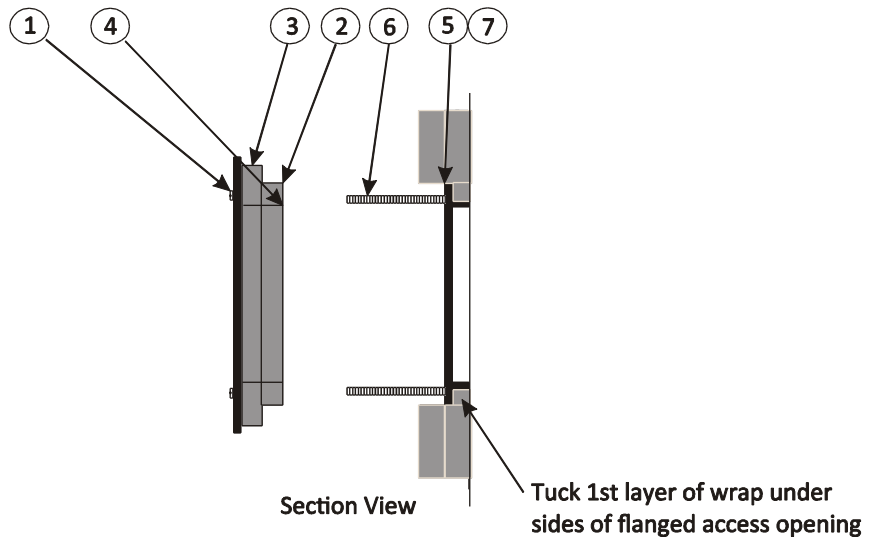



### Prefabricated Access Panel Detail #1

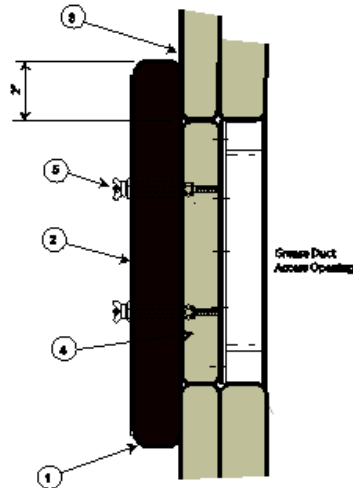

For installation over a standard NFPA-96 installed grease duct access door assembly or alternately can be installed over a ventilation air duct access door assembly.

1. Square, Rectangular, or Round \*CL4FIRE Access panel cover 1 1/2" (38mm) thick extending a minimum of 2" (50mm) over CL4FIRE insulation in all directions and snugly installed over \*CL4FIRE Fire Rated Thermal Insulation as per manufacturer's instructions.
2. Install minimum #16 gauge steel plate over access panel cover item #1.
3. \*CL4FIRE Fire Rated Thermal Insulation installed to closely surround the access panel or frame.
4. Fabricate a piece of CL4FIRE insulation 1/2" larger than the size of the access panel cover plate and compress into the opening.
5. \*CL4FIRE Panel is attached by minimum of (4) equally spaced 1/4" (6mm) or larger threaded rods or steel threaded bolts welded to the access panel cover plate. \*CL4FIRE rated panel and #16-gauge cover plate can also be attached using min. 1/4" (6mm) cover plate retaining bolts extended with threaded couplings. Retain the \*CL4FIRE panel and #16-gauge steel plate using bolts or wing nuts.

**CL4FIRE Grease Duct 1 or 2-hour fire rated wall or floor penetrations:**

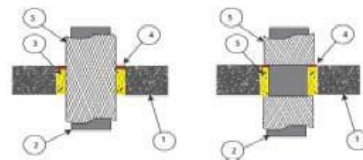
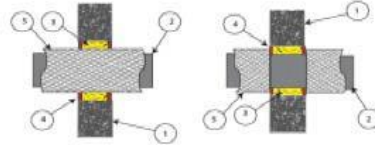
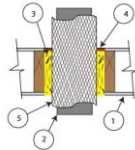
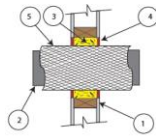

**Gypsum/Wood Firestop Assemblies**

**Concrete Firestop Assemblies**

**1. Floor or Wall Assemblies:**

Code conforming 1 or 2-hour floor or wall assembly. Minimum 4 ½” thick lightweight or normal weight concrete, 8” thick concrete block (filled or unfilled), 1 or 2 hour gypsum wall assembly with framed opening, 1 or 2 hour gypsum ceiling / wood floor assembly with framed opening.

**2. Penetrating Item:**

Rectangular or Round #16 gauge or thicker steel grease duct (as described in Maximum Size of Grease Duct System)

**3. Wall Firestop Insulation:**

Minimum 4” thickness of CL4FIRE fire protection thermal insulation, or mineral wool insulation tightly compressed into concrete opening, recessed ¼” from the top and flush with the bottom of a gypsum ceiling / wood floor assembly, or recessed ¼” from both sides of a concrete or framed gypsum wall assembly.

**4. Firestop Sealant:**

Firestop Sealant installed a minimum of ¼” deep flush with the top surface of a floor assembly or both sides of a wall assembly. Installation can consist of one of the approved caulking products:

**Approved Sealants:**

- 3M Fire Barrier 1000 Silicone
- AD Fire Barrier Silicone
- Passive Fire Protection Partners 4800DW Sealant
- STi SIL300 Silicone Firestop Sealant
- STi SpecSeal® Series SSS Latex Intumescent Sealant
- STi SpecSeal® Series LCI Intumescent Sealant

**5. Duct Insulation:**

**Gypsum/wood Assemblies:**

Duct must be wrapped with CL4Fire insulation entirely through gypsum/wood floor or wall openings.

**Concrete Assemblies:**

Ducts may be wrapped with CL4FIRE insulation entirely through the concrete floor or wall openings before firestopping or abut to both sides of the firestopped floor or wall assembly.