



PUBLISHED: February 2022
REVISED: March 2024
EXPIRATION: March 2027

PRODUCT: LOGIX and ELEMENT™ INSULATED CONCRETE FORMS (ICF)

REPORT HOLDER: Logix Brands, Ltd.

CONTACT DETAILS: 9242 Pinetree Place
Whistler, British Columbia
V8E 0G5 Canada
www.logixbrands.com

CSI DIVISION: 03 00 00 – Concrete
07 00 00 – Thermal and Moisture Protection

CSI SECTION: 03 11 19 - Insulating Concrete Forming
07 21 00 – Thermal Insulation

APPLICABLE CODES: 2021, 2018, 2015 International Building Code (IBC)
2021, 2018, 2015 International Residential Code (IRC)
2018, 2015 International Energy Code (IEC)
2019 California Green Building Standards Code (CALGreen), Title 24, Part 11
2015, 2012 ICC 700 National Green Building Standard™ (ICC 700)
2023, 2020 Florida Building Code, Building
2023, 2020 Florida Building Code, Residential

EVALUATED: Flat Walled Insulated Concrete Forms
Foam Plastic, Surface Burning Characteristics
Foam Plastics, Use in Exterior Walls in Types I-IV Construction
Foam Plastics, Use in Attics and Crawlspace
Plastics, Ignition Temperature
Plastics, Rate of Burning
Fire-Resistance Ratings



QAI LABORATORIES

LOS ANGELES | TULSA | MIAMI | TORONTO | VANCOUVER | SEQUOIA | SHANGHAI



CODE EVALUATION REPORT

1.0 APPROVED FOR FOLLOWING:

APPROVED TYPES OF CONSTRUCTION:	Types I-V A/B
APPROVED USE:	Stay-in-place Concrete Forms
APPROVED INSTALLATIONS:	<ul style="list-style-type: none"> • Load Bearing and Non-load Bearing Exterior and Interior Walls • Load Bearing and Non-load Bearing Fire-Resistance Rated Walls • Foundation Walls • Retaining Walls • Attic and Crawlspace installations without Code Prescribed Ignition Barrier

2.0 DESCRIPTION:

2.1 General:

Logix ICF and Element™ Insulated Concrete Forms (ICF) are modular concrete formworks comprised of Type II expanded polystyrene (EPS) foam plastic thermal insulation panels connected with high density plastic cross ties. Logix and Element™ ICF are placed onsite as stay-in-place forms for concrete placement.

Logix ICF and Element™ ICF meet *Flat Wall Insulated Concrete Forms* specifications, as defined in Section 1903.4 of the 2021 / 2018 / 2015 IBC, and Sections R404.1.3.3.6.1 and R608.4.4 of the 2021 / 2018 / 2015 IRC through compliance to ASTM E2634.

Logix ICF are available in the following products and sizes:

Table 1a. LOGIX ICF Evaluated Products and Accessories¹

Concrete Core Thickness		Length		Height		Style
inches	mm	inches	mm	inches	mm	
4, 6.25, 8, 10, 12	102, 159, 203, 254, 305	48	1219	12 16	305 406	Standard Straight
4, 6.25, 8, 10, 12	102, 159, 203, 254, 305	48	1219	16	406	Brick Ledge Block
4, 6.25, 8, 10, 12	102, 159, 203, 254, 305	48	1219	12 16	305 406	Taper Top Block
4, 6.25, 8, 10, 12	102, 159, 203, 254, 305	48	1219	16	406	Double Taper Top Block
4, 6.25, 8, 10	102, 159, 203, 254	32	813	12 16	305 406	90° Block
4, 6.25, 8	102, 159, 203	30	762	16	406	45° Block

¹: Additional Logix ICF accessories, including but not limited to half height ICF, T-series blocks, and end caps are available for use with Logix ICF products.



CODE EVALUATION REPORT

Element™ ICF are available in the following products and sizes:

Table 1b. ELEMENT™ ICF Evaluated Products and Accessories¹

Concrete Core Thickness		Length		Height		Style
inches	mm	inches	mm	inches	mm	
4, 6, 8, 10, 12	102, 152, 203, 254, 305	48	1219	16	406	Standard Straight
4, 6, 8, 10, 12	102, 152, 203, 254, 305	48	1219	16	406	Brick Ledge Block
4, 6, 8, 10, 12	102, 152, 203, 254, 305	48	1219	16	406	Taper Top Block
4, 6, 8, 10, 12	102, 152, 203, 254, 305	38.5	978	16	406	90° Block

Logix ICF and Element™ ICF comply for use as Flat Wall ICF including use in High Velocity Hurricane Zones as defined by the 2023 / 2020 Florida Building Code and 2023 / 2020 Florida Building Code, Residential. See Section 9 of this report for further details.

2.2 EPS Foam Plastic Panels:

Logix ICF and Element™ ICF include expanded polystyrene (EPS) *foam plastic* thermal insulation panels of 2-3/4 inches (70 mm) thickness on each ICF face. The EPS *foam plastic* component has a flame spread index of 25 or less, and smoke developed index of 450 or less evaluated following ASTM E84.

The EPS foam is listed by an *approved agency* and complies with Type II specifications per ASTM C578 for use as thermal insulation.

Logix ICF and Element™ ICF foam plastic has spontaneous ignition temperatures > 650°F (343°C) when evaluated to ASTM D1929.

2.3 Cross Ties:

Logix ICF and Element™ ICF include polypropylene cross ties spaced at 8 inches (203 mm), molded into the EPS panels, connecting EPS panels to create the molded concrete form work. Cross ties allow concrete flow through during concrete placement, and are molded to include rebar slots for ease of rebar placement. Additionally, the polypropylene cross ties include a flange molded into the EPS panels, providing an anchoring substrate for mechanical fasteners to connect interior finishes, exterior claddings, and decorum. Fasteners evaluated for use with Logix ICF and Element™ ICF are outlined in Tables 3a and 3b of this report including fastener capacities. Locations of cross tie flanges are outlined in Logix ICF and Element™ ICF EPS panel faces to provide direction during fastener installation.

Logix ICF and Element™ ICF cross ties have spontaneous ignition temperatures ≥ 650°F (343°C) when tested to ASTM D1929, a smoke density index less than 75 when tested to ASTM D2843 and are classified as minimum CC2 when tested to ASTM D635.

2.4 Concrete Core:

Concrete is placed at the jobsite. Concrete design, specifications and applications are to be in accordance with the project requirements per the applicable code(s) and are outside the scope of this report, except where specific concrete criteria are noted.

2.5 Rebar (reinforcement):

Reinforcement is applied at the jobsite. Reinforcement design, specifications and installation are to be in accordance with the project requirements and applicable code(s), and are outside the scope of this report.



3.0 DESIGN:

Logix ICF and Element™ ICF wall design including concrete and reinforcement is outside the scope of this report. See below for information regarding design criteria for use with Logix ICF and Element™ ICF.

2021 / 2018 / 2015 IBC: Logix ICF and Element™ ICF construction governed by the IBC are to have concrete walls designed in accordance with Chapters 16 and 19. Where used as footings or foundations, design shall be in accordance with Chapter 18.

2021 / 2018 / 2015 IRC: Logix ICF and Element™ ICF construction governed by the IRC are to have concrete walls designed in accordance with Section R608. Where used as footings or foundations, design shall be in accordance with IRC Chapter 4.

4.0 INSTALLATIONS:

4.1 General:

Installation of Logix ICF and Element™ ICF must comply with the manufacturer's published installation instructions, this report, and the applicable code(s). Where conflicts exist, this report and the applicable building code shall govern.

Logix ICF and Element™ ICF construction designed in accordance with 2021 / 2018 / 2015 IBC and 2021 / 2018 / 2015 IRC require special inspections as defined by Section 1705 of the IBC.

Logix ICF and Element™ ICF construction conducted following IRC prescriptive methodology does not require special inspections. The authority having jurisdiction should be consulted in case of question.

4.2 Interior:

4.2.1 General:

Logix ICF and Element™ ICF components located on the interior of the building are to be installed in accordance with section 4.2.2 and 4.2.3 of this report, as appropriate. Connecting of interior decorum, furniture and cabinetry are approved where the necessary load resistance for objects secured to Logix ICF and Element™ ICF are provided by fasteners as outlined in Tables 3a and 3b of this report. Service loads shall not exceed the allowable load carrying capacity of the fasteners noted.

4.2.2 Occupied Space:

4.2.2.1 Use With a Code Prescribed Thermal Barrier.

2021 / 2018 / 2015 IBC: Logix ICF and Element™ ICF EPS thermal insulation exposed to occupancies of the building interior shall be covered by a thermal barrier of minimum ½ inch (13 mm) thick gypsum board complying with ASTM C1396, or by a material complying with NFPA 275 compatible for use with the Type II EPS insulation at thicknesses of 2-¾ inches (70 mm) or greater. Gypsum shall be mechanically connected to the Logix ICF and Element™ ICF cross ties with fasteners outlined in Tables 3a and 3b of this report, with the gypsum oriented either vertically or horizontally. When used in applications not requiring fire-resistance ratings, the gypsum boards are to be secured with fasteners spaced at 12 inches (305 mm) on center vertically and horizontally, with fasteners penetrating the cross-tie flanges of the underlying Logix ICF and Element™ ICF. Joint treatment is not required. Where Logix ICF and Element™ ICF are constructed in applications requiring fire-resistance rating, attachment of the gypsum membrane and joint treatment shall follow Section 4.4 and Section 8.2 of this report.



2021 / 2018 / 2015 IRC: Logix ICF and Element™ ICF EPS thermal insulation exposed to occupancies of the building shall be protected by a thermal barrier of minimum of ½ inch (13 mm) thick gypsum wall board complying with ASTM C1396, 23/32-inch thickness structural wood panels, or a material complying with NFPA 275 compatible for use with the Type II EPS insulation at thicknesses 2-¾ inches (70 mm) or greater. Where gypsum or structural wood panels are used, they shall be mechanically connected to the Logix ICF and Element™ ICF cross ties with fasteners outlined in Tables 3a and 3b of this report, with panels oriented either vertically or horizontally. When used in applications not requiring fire-resistance ratings, the gypsum boards are to be secured with fasteners spaced at 12 inches (305 mm) on center vertically and horizontally, with fasteners penetrating the cross-tie flanges of the underlying Logix ICF and Element™ ICF. Joint treatment is not required. Where Logix ICF and Element™ ICF are constructed in applications requiring fire-resistance ratings, attachment of the gypsum membrane and joint treatment shall follow Section 4.4 and Section 8.2 of this report.

4.2.2.2 Use Without a Code Prescribed Thermal Barrier.

No alternative thermal barriers are approved under this current report over Logix ICF and Element™ ICF.

4.2.3 Attic and Crawlspace:

4.2.3.1 Use With a Code Prescribed Ignition Barrier:

Logix ICF and Element™ ICF EPS thermal insulation exposed in attics and crawlspaces is to be protected with a code prescribed ignition barrier as defined in the Section 2603.4.1.6 of the 2021 / 2018 / 2015 IBC and Sections R316.5.3 and R316.5.4 of the 2021 / 2018 / 2015 IRC. The ignition barrier is to cover all exposed foam.

4.2.3.2 Use Without a Code Prescribed Ignition Barrier:

Logix ICF and Element™ ICF EPS thermal insulation panels exposed in attics and crawlspaces can be installed without the prescribed ignition barrier as defined in the 2021 / 2018 / 2015 IBC and 2021 / 2018 / 2015 IRC, only when the following conditions are present:

- Entry to the attic or crawlspace is limited to service of utilities only. Storage or occupancy are not permitted.
- No interconnected areas exist to the attic or crawlspace.
- Air from the attic or crawlspace is not circulated to other areas of the building.
- Ventilation is provided as required by 2021 / 2018 / 2015 IBC Chapter 12 or 2021 / 2018 / 2015 IRC Section R306.
- Combustion air is provided in accordance with the IMC (International Mechanical Code) Section 701.
- Labels at minimum 1 per location, or 1 label per 160 ft² exposed foam, which ever greater, is present outlining product as "*Approved for Use in Attic and Crawlspace*". See Figure 1a of this report for an example of approved Logix ICF label. See Figure 1b of this report for an example of approved Element™ ICF label.



4.3 Exterior:

4.3.1. Above Grade:

4.3.1.1 Exterior Walls: Exterior walls of Logix ICF and Element™ ICF shall comply with Sections 4.3.1.2 through 4.3.1.4 of this report. Where Logix ICF and Element™ ICF is used in fire-resistance rated construction, installation shall comply with Sections 4.4 and 8.2 of this report. Where Logix ICF and Element™ ICF is used in Types I-IV construction, installation shall be in accordance with Section 4.5 of this report.

4.3.1.2 Weather Protection: Logix ICF and Element™ ICF used as exterior walls require installation with a approved exterior cladding and flashings for providing weather protection in accordance with Section 1402.2 of the 2021 / 2018 IBC, Section 1403.2 of the 2015 IBC and water resistance in accordance with Section R703.1.1 of the 2021 / 2018 / 2015 IRC. Exterior cladding materials shall comply with Section 1403 of the 2021 / 2018 IBC, Section 1404 of the 2015 IBC and R703 of the 2021 / 2018 / 2015 IRC, or have means for showing compliance to the noted applicable code. Anchoring of the exterior cladding and trim shall be done with approved fasteners outlined in Tables 3a and 3b of this report as appropriate, with the fastener spacing appropriate for ensuring anchorage capacities are within the specified allowable values. The water resistive barrier can be omitted in accordance with Section 1402.2 of the 2021 / 2018 IBC or 1403.2 of the 2015 IBC, and R703.1.1 of the 2021 / 2018 / 2015 IRC as applicable.

4.3.1.3 Vapor Retarders: Logix ICF and Element™ ICF EPS component is a Type II vapor retarder at a total installed EPS thickness of 5.5 inches (140 mm), so where a Class II vapor retarder is required, this can be omitted.

4.3.1.4 Termite Protection: Where Logix ICF and Element™ ICF are installed in areas defined as “very heavy” as indicated in Figure 2603.8 of the 2021 / 2018 / 2015 IBC and Figure R301.2(6) of the 2021 / 2018 / 2015 IRC, and where the EPS foam component is located within 6 inches (152 mm) above grade from exposed earth, construction is to follow Section 2603.8 of the 2021 / 2018 / 2015 IBC and R318.4 of the 2021 / 2018 / 2015 IRC. This construction requires all structural elements of walls, floors, ceilings and roofs to be of noncombustible materials or preservative-treated wood, unless an approved method of protecting the foam plastic from subterranean termite damage is provided to the authority having jurisdiction.

4.3.2. Below Grade:

4.3.2.1 Walls: For foundation walls designed as freestanding, backfill is permitted prior to floor installation. For below grade walls relying on the floor for structural support, backfill is not permitted until the floor installation is complete.

Foundation walls and footings are to be designed and installed in accordance with 2021 / 2018 / 2015 IBC Chapter 18 or 2021 / 2018 / 2015 IRC Section R404, as applicable. Foundation walls supporting steel or wood framed constructions require appropriate protection to the framing members as required by the applicable code.

Retaining walls are to be designed and installed in accordance with 2021 / 2018 / 2015 IBC Chapter 1807. Where used as retaining walls under the IRC, the authority having jurisdiction should be consulted.

4.3.2.2 Dampproofing or waterproofing: As required by site conditions, dampproofing or waterproofing shall be installed in accordance with 2021 / 2018 / 2015 IBC Chapter 1805 or 2021 / 2018 / 2015 IRC Section R406 as applicable. The dampproofing or waterproofing material must be compatible for use with EPS thermal insulation products.



4.3.2.3 Termite Protection: Where Logix ICF and Element™ ICF are used below grade in areas defined as “very heavy” termite infestation probability as indicated in Figure 2603.8 of the 2021 / 2018 / 2015 IBC and Figure R301.2(6) of the 2021 / 2018 / 2015 IRC, construction is to follow Section 2603.8 of the 2021 / 2018 / 2015 IBC and R318.4 of the 2021 / 2018 / 2015 IRC. This construction requires all structural elements to walls, floors, ceilings and roofs to be of noncombustible materials or preservative-treated wood unless an approved method of protecting the foam plastic from subterranean termite damage is provided to the authority having jurisdiction.

4.4. Fire-Resistance-Rated Construction:

Logix ICF and Element™ ICF are approved for use in applications where a load-bearing fire-resistance-rating is required for up to 4 hours interior or exterior orientated towards the fire.

See Section 8.2 of this report for details of installation for use in fire-resistance-rated applications.

4.5 Type I-IV (Non-combustible) Construction:

4.5.1 General:

Logix ICF and Element™ ICF are approved for use in exterior walls of Types I-IV (non-combustible) construction.

All exterior claddings systems require a thermal barrier applied on the occupancy (interior) face, in accordance with Section 4.2.2.1 of this report.

Fire blocking is required in interior areas at maximum each floorline, to limit the spread of flames and smoke from one compartment to another.

4.5.2 Exterior Insulation Finishing Systems (EIFS):

When used with EIFS systems as outlined below where no additional EPS is included in the EIFS assembly, backwrapping and installation of the EIFS lamina are to follow the EIFS manufacturer’s published installation instructions.

Where additional EPS is applied over Logix ICF and Element™ ICF, the Logix ICF and Element™ ICF exterior foam plastic component must be considered in calculating an equivalent fuel load as nominal 1.5 lbs/ft³ (24 kg/m³) density to the approved expanded polystyrene fuel load component of the approved EIFS.



CODE EVALUATION REPORT

Table 2. Details of EIFS systems approved for use with Logix ICF and Element™ ICF include:

EIFS PRODUCT	EIFS MANUFACTURER	MAXIMUM EIFS EPS THICKNESS* (TYPE I @ 1.0 lb/ft ³)	LOGIX ICF AND ELEMENT™ ICF EPS THICKNESS (TYPE II @ 1.5 lbs/ft ³)	MAXIMUM APPLIED EPS THICKNESS FINISHED EIFS**
Owens Corning®	Dryvit Corporation Inc.	9 inches (229 mm)	2-3/4 inches (70 mm)	11-3/4 inches (298 mm)
Owens Corning® MD	Dryvit Corporation Inc.	9 inches (229 mm)	2-3/4 inches (70 mm)	11-3/4 inches (298 mm)
StoTherm Classic	Sto Corporation	8 inches (203 mm)	2-3/4 inches (70 mm)	10-3/4 inches (273 mm)
StoTherm Classic Next™ ci	Sto Corporation	8 inches (203 mm)	2-3/4 inches (70 mm)	10-3/4 inches (197 mm) when over 1/2 inch (13 mm) interior and exterior gypsum.
		5 inches (127 mm)	2-3/4 inches (70 mm)	7-3/4 inches (197 mm) when installed over TurboStick adhesive.

* Maximum thickness of EIFS (Type 1 @ 1.0 lb/ft³) when applied over Logix ICF and Element™ ICF.

** Maximum combined insulation total thickness of EIFS and Logix / Element™ ICF EPS.

EPS thickness above is provided considering combined Logix ICF and Element™ ICF EPS component with EIFS EPS component providing equivalent fuel load to above described Type I-IV approved EIFS assemblies. Manufacturer's installation instructions for application with EIFS including backwrap details are to be followed during installation, with backwrap anchoring and overlaps required, connected at competent anchor points. Anchoring of backwraps to the face of Logix ICF and Element™ ICF EPS component when installed in Types I-IV construction is not permitted.

4.5.3 Exterior Brick Veneer:

Brick veneer is to be anchored to Logix ICF and Element™ ICF cross ties with fasteners required to penetrate the cross tie flange. Anchoring schedules used shall be designed to resist the anticipated gravity and service loads based on fastener capacity values outlined in Tables 3a and 3b of this report. Brick veneer used is to comply with 2021 / 2018 / 2015 IBC, and shall be installed with a minimum 1 inch (25 mm) air gap between the exterior Logix ICF and Element™ ICF EPS panel face, and the brick veneer. Brick veneer is to be supported along floor lines in accordance with the applicable code.

4.5.4 Exterior Plaster:

Exterior plaster including metal lath is to comply with the applicable code, and shall be a minimum of 7/8 inch (22.2 mm) thickness. Fasteners connecting the metal lath to Logix ICF and Element™ ICF cross ties are required to penetrate the cross-tie flanges. Anchoring schedules used shall be designed to resist the anticipated gravity and service loads based on fastener capacity values outlined in Tables 3a and 3b of this report.



5.0 LIMITATIONS

- Logix ICF and Element™ ICF are to be protected from direct sunlight exposure to the plastic cross ties.
- Logix ICF and Element™ ICF are manufactured in Chilliwack, BC, Acheson, AB, Headingly, MB, Cobourg, ON, Hayesville, KS and McFarland, CA with inspections by QAI Laboratories.
- Logix ICF and Element™ ICF are required to be separated from interior space by an approved thermal barrier when installed in accordance with Section 4.2.2 of this report and the applicable code
- Logix and Element™ ICF are approved for use in Attic and Crawlspace applications when installed in accordance with Section 4.2.3 of this report and the applicable code and where products bear a visible label outlining “*Approved for Use in Attics and Crawlspaces*”.
- Logix ICF and Element™ ICF are required to be protected by a code-compliant exterior cladding when installed on the exterior of the building above grade, or code compliant dampproofing and waterproofing material when installed on the exterior below grade. Refer to section 4.3 of this report for details.
- Logix ICF and Element™ ICF exposed within 6 inches (152) of grade or below grade in termite infestation areas defined as “very heavy” require protection in accordance with IBC Section 2603.8 or IRC R318.4 with installation required in accordance with Sections 4.3.1.4 and 4.3.2.3 of this report and the applicable code, as appropriate.
- Logix ICF and Element™ ICF when used in fire-resistance-rated construction are to be installed in accordance with Section 4.4 and Section 8.2 of this report.
- Logix ICF and Element™ ICF used in Types I-IV Construction are to be installed in accordance with Section 4.5 of this report.
- Logix ICF and Element™ ICF have product labels visible at minimum every 160 ft².

6.0 SUPPORTING INFORMATION:

The following data has been evaluated for Logix ICF and Element™ ICF:

- Data outlining compliance for use as Flat Wall Insulated Concrete Forms, as detailed in ASTM E2634.
- Data outlining determination of flame spread index and smoke developed index per ASTM E84.
- Data outlining details for use in load-bearing fire-resistance rated construction per ASTM E119.
- Data outlining details for use in exterior walls of Types I-IV construction as detailed in Chapter 26 of 2021 / 2018 / 2015 IBC.



CODE EVALUATION REPORT

7.0 MARKING:

Logix ICF finished products example label are outlined in Figure 1a below.

LOGIX™
INSULATED CONCRETE FORMS
www.logixicf.com
1-XXX-XXXX
Manufactured in XXXX

	USA		CANADA	
	METHOD	RESULTS	METHOD	RESULTS
Surface Burning Characteristics	UL 723	Flame Spread: ≤ 25 Smoke Developed ≤ 450	ULC S102.2	Flame Spread: ≤ 250 Smoke Developed ≤ 500
Type	ASTM C576	Type II	ULC S201.1	Type 2
Flat Wall ICF	ASTM E2534	Compliant	ULC S273.1	Compliant
Thermal Resistance	ASTM C518	R-22.7	ASTM C518	≥ 0.851
Adhesive and Cracking Use	Evaluated for use without a code prescribed ignition barrier.		N/A	

EVALUATIONS
 - Wisconsin Building Products #201307-4
 - MEA 273-04
 - Florida Product Approval FL2931
 - Miami-Dade NOA No. 09-0714.03
 - LA RR #25518
 - QAI Evaluation Report xxx

Shift: DA: MO: YR: OP: MACH#:

8"

Description

- Std.
- 90° Corner
- 45° Corner
- 1/2 Ht Std.
- 1/2 Ht 90° Corner
- 1/2 Ht 45° Corner
- End Cap
- Taper Top
- Double Taper top
- Brick Ledge
- Pro Buck
- Other

Figure 1a. Example of Logix ICF Finished Product Label

Element™ ICF finished products example label are outlined in Figure 1b below.

ELEMENT
ICF
www.logixicf.com
1-877-789-7622
Manufactured in Headingley, MB

	USA		CANADA	
	METHOD	RESULTS	METHOD	RESULTS
Surface Burning Characteristics	UL 723	Flame Spread: ≤ 25 Smoke Developed ≤ 450	ULC S102.2	Flame Spread: ≤ 250 Smoke Developed ≤ 500
Type	ASTM C576	Type II	ULC S201.1	Type 2
Flat Wall ICF	ASTM E2534	Compliant	ULC S273.1	Compliant
Thermal Resistance	ASTM C518	R-22.7	ASTM C518	≥ 0.851
Adhesive and Cracking Use	Evaluated for use without a code prescribed ignition barrier.		N/A	

EVALUATIONS
 - Wisconsin Building Products Approval #201307-4
 - MEA 273-04-M
 - Florida Product Approval FL18469-RS
 - Miami-Dade County Product Control Approved NOA 21-1117.08
 - LA RR #25518
 - QAI Evaluation CERus 1005-QAI 08/24/2024

Shift: DA: MO: YR: OP: MACH#:

6"

Description

- Standard
- 90 Corner
- Taper Top
- Brick Ledge
- Pro Buck

Figure 1b. Example of Element™ ICF Finished Product Label



CODE EVALUATION REPORT

8.0 RESULTS / RATINGS:

8.1 Allowable Fastener Capacities

Table 3a. Logix ICF Approved Fasteners Including Capacities

FASTENERS ¹	FASTENER CAPACITY	
	Allowable Withdrawal lbs (kg)	Allowable Lateral Shear lbs (kg)
#6 Coarse Thread Drywall Screw	23 (10)	59 (26)

Table 3b. Element™ ICF Approved Fasteners Including Capacities

FASTENERS ¹	FASTENER CAPACITY	
	Allowable Withdrawal lbs (kg)	Allowable Lateral Shear lbs (kg)
#6 Coarse Thread Drywall Screw	37 (17)	40 (18)
#6 Fine Thread Drywall Screw	34 (15)	21 (10)
#8 Wood Screw	40 (18)	46 (21)
#10 Wood Screw	42 (19)	30 (14)

Note 1: Fasteners must penetrate the cross ties flanges, and should be specified as ¾ inches (76 mm) longer than object through which the fastener is penetrating.

8.2 Fire-Resistance-Rated Assembly Details

Table 4. Logix ICF and Element™ ICF Load-Bearing Fire-Resistance-Rated Assemblies.

Wall Type	ASSEMBLY RATING (Hours)	MINIMUM CONCRETE CORE (MM)	MINIMUM CONCRETE CORE (INCHES)
Logix ICF	2	102	4
	3	159	6.25
	4	203	6.25*
Element™ ICF	2	102	4
	3	152	6
	4	203	8

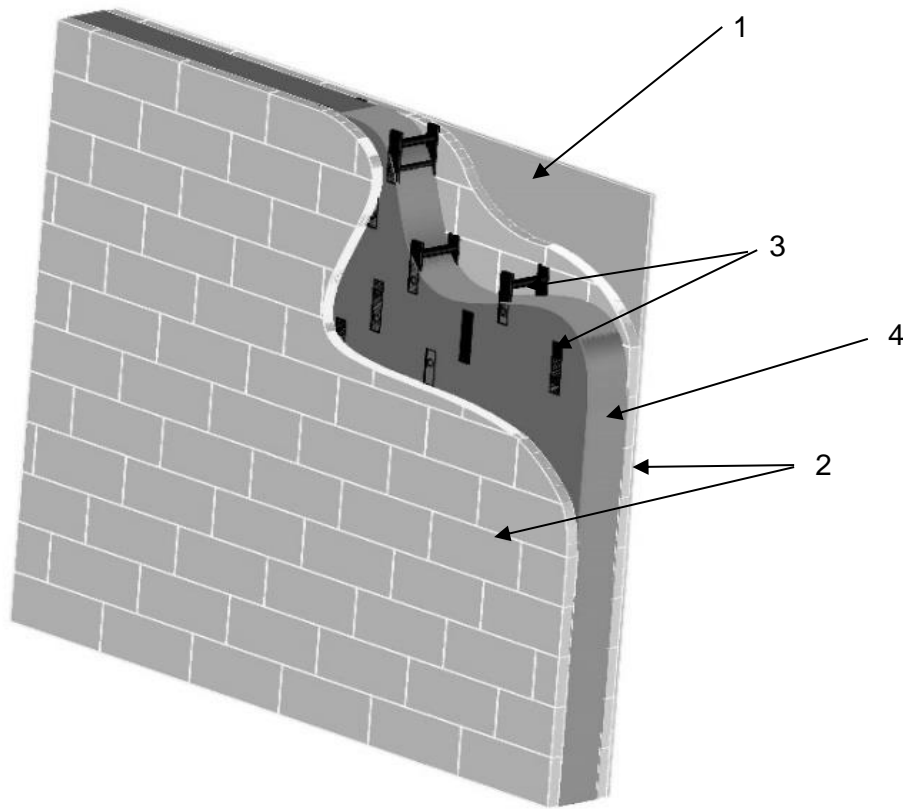



CODE EVALUATION REPORT

NO.	COMPONENT	DESCRIPTION
1	Interior Finish	<p>Minimum ½ inch (12 mm) thickness ASTM C1396 listed gypsum wall board, installed with minimum 2 inches (51 mm) length coarse thread drywall screws spaced at maximum 16 inches (406 mm) on center horizontally and vertically.</p> <p>*For Logix 6 ¼ inch (159 mm) products used in 4-hour load-bearing fire-resistance-rated wall assemblies, listed 5/8-inch (16 mm) thickness Type X gypsum wall board complying with ASTM C1396 is required with fastening requirements as noted above.</p> <p>Gypsum joints and fasteners are required taped and mudded per industry standard.</p>
2	Expanded Polystyrene (EPS) Insulation	<p>Maximum 2 ¾ inches (70 mm) thickness Type II (per ASTM C578) expanded polystyrene thermal insulation. Logix ICF and Element™ ICF EPS panels have interlocking teeth to allow stacking onsite to create the forming wall.</p>
3	Cross Ties	<p>Logix and Element™ polypropylene cross ties, spaced at 8 inches (203 mm) on center spacing through Logix and Element™ ICF. Cross ties can be stacked or staggered vertically during installation (staggered cross tie system shown).</p>
4	Concrete Core	<p>Minimum core thickness as outlined in the Table 4, using 3,000 psi (20 MPa) compressive strength concrete at 28 days. Steel reinforcing, while not shown, is approved for use. Reinforcing is to be designed and approved by a registered design professional, or authority having jurisdiction in accordance with the applicable code.</p>
5	Exterior Sheathing (Not Shown)	<p>*For Logix 6 ¼ inch (159 mm) products used in 4-hour load-bearing fire-resistance-rated wall assemblies, listed 5/8-inch (16 mm) thickness Type X gypsum wall board complying with ASTM C1396 or ASTM C1177 is required with fastening requirements as noted above.</p> <p>Taping and mudding of joints and fasteners is optional.</p>
6	Exterior Cladding (Not Shown)	<p>Exterior claddings are approved for use with the Logix ICF and Element™ ICF load-bearing fire-resistance-rated wall assemblies without negatively impacting the fire rating. These exterior claddings include: brick veneer, stucco, fire rated exterior insulating finish systems, cultured stone, aluminum and steel products. All exterior claddings are to be installed with the applicable building code, and the manufacturer's approved installation instructions.</p>

Note 1: The allowable load for Logix ICF and Element™ ICF load-bearing fire-resistance rated assemblies are to be determined by a registered design professional, or authority having jurisdiction in accordance with the applicable codes.

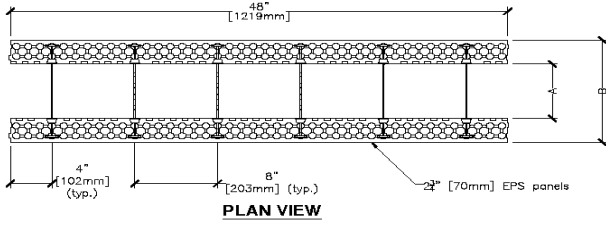

PLAN VIEW

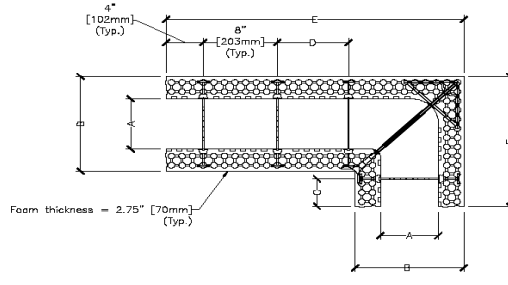

PLAN VIEW

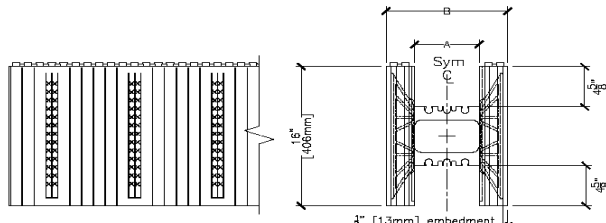

SIDE ELEVATION

END VIEW

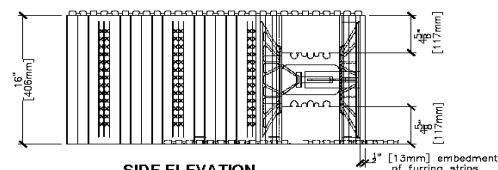

SIDE ELEVATION

END VIEW

	FORM SIZES, in (mm)				
	4 (102)	6.25 (159)	8 (203)	10 (254)	12 (305)
Dimension A, in (mm)	4 (102)	6.25 (159)	8 (203)	10 (254)	12 (305)
Dimension B, in (mm)	9.5 (241)	11.75 (298)	13.5 (343)	15.5 (395)	17.5 (445)
Conc. Vol. (y ³)	0.065	0.103	0.132	0.165	0.198
Conc. Vol. (ft ³)	1.778	2.778	3.556	4.444	5.333
Conc. Vol. (m ³)	0.050	0.079	0.101	0.126	0.151

NOTES:

1. Wall area per block or panel = 5.333 ft²
2. Forms are available as assembled (LOGIX PRO) or unassembled (or knock-down) form blocks (LOGIX KD Product drawings).
3. Concrete core thickness wider than 12" (305mm) are available using LOGIX Xtenders (See Logix Xtender Product drawing).
4. 6 1/4" [159mm] LOGIX Form shown.

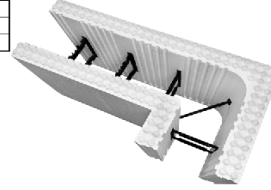
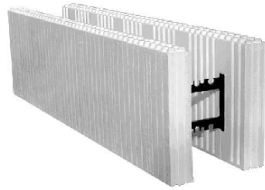

	FORM SIZES, in (mm)				
	4 (102)	6.25 (159)	8 (203)	10 (254)	12 (305)
Dimension A, in (mm)	4 (102)	6.25 (159)	8 (203)	10 (254)	12 (305)
Dimension B, in (mm)	9.5 (241)	11.75 (298)	13.5 (343)	15.5 (395)	17.5 (445)
Dimension C, in (mm)	3.5 (89)	3.375 (86)	2.25 (57)	2.125 (54)	
Dimension D, in (mm)	7.67 (195)	7.67 (195)	6.125 (156)	5.875 (149)	
Dimension E, in (mm)	32.125 (816)	32.125 (816)	32.125 (816)	34.5 (876)	
Dimension F, in (mm)	16.125 (410)	16.125 (410)	16.125 (410)	18.5 (470)	
Conc. Vol. (y ³)	0.053	0.073	0.095	0.128	
Conc. Vol. (ft ³)	1.419	2.096	2.588	3.456	
Conc. Vol. (m ³)	0.040	0.059	0.072	0.098	
Outside Corner Wall Area (ft ²)	5.361	5.361	5.361	5.889	
Inside Corner Wall Area (ft ²)	3.250	2.750	2.361	2.444	

NOTES:

1. Forms are available as assembled (LOGIX PRO) or unassembled (or knock-down) form blocks (LOGIX KD Product drawings).
2. Concrete core thickness wider than 12" (305mm) are available using LOGIX Xtenders (See Logix Xtender Product drawing).
3. 6 1/4" [159mm] LOGIX Corner Form shown.

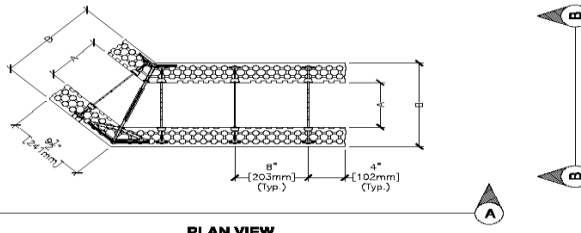

PLAN VIEW

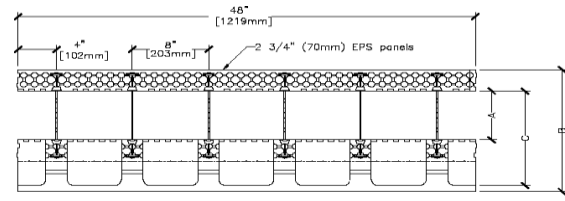

PLAN VIEW

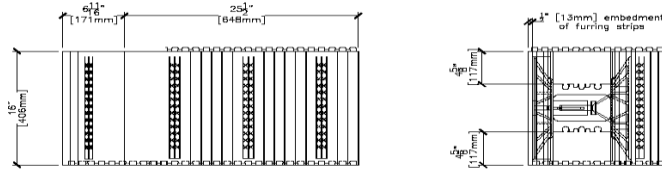

ELEVATION A-A

ELEVATION B-B

For clarity knobs partially removed in elevation views.

	FORM SIZES, in (mm)		
	4 (102)	6.25 (159)	8 (203)
Dimension A, in (mm)	4 (102)	6.25 (159)	8 (203)
Dimension B, in (mm)	9.5 (241)	11.75 (298)	13.5 (343)
Conc. Vol. (y ³)	0.043	0.065	0.081
Conc. Vol. (ft ³)	1.151	1.744	2.178
Conc. Vol. (m ³)	0.033	0.049	0.062
Outside Corner Wall Area (ft ²)	3.889	3.889	3.889
Inside Corner Wall Area (ft ²)	3.014	2.807	2.646

NOTES:

1. Forms are available as assembled (LOGIX PRO) or unassembled (or knock-down) form blocks (LOGIX KD Product drawings).
2. Concrete core thickness wider than 12" (305mm) are available using LOGIX Xtenders (See Logix Xtender Product drawing).
3. 6 1/4" [159mm] LOGIX Form shown.
4. Corner web not available with 4" 45deg Corner Forms.

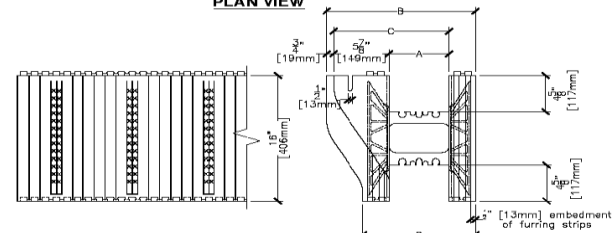
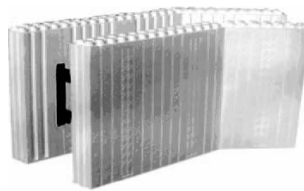

SIDE ELEVATION

END VIEW

	FORM SIZES, in (mm)				
	4 (102)	6.25 (159)	8 (203)	10 (254)	12 (305)
Dimension A, in (mm)	4 (102)	6.25 (159)	8 (203)	10 (254)	12 (305)
Dimension B, in (mm)	13.325 (338)	15.625 (397)	17.375 (441)	19.375 (492)	21.375 (543)
Dimension C, in (mm)	9.875 (251)	12.125 (308)	13.875 (352)	15.875 (403)	17.875 (454)
Dimension D, in (mm)	9.5 (241)	11.75 (298)	13.5 (343)	15.5 (394)	17.5 (445)
Conc. Vol. (y ³)	0.073	0.110	0.139	0.172	0.205
Conc. Vol. (ft ³)	1.967	2.987	3.745	4.633	5.522
Conc. Vol. (m ³)	0.156	0.084	0.106	0.131	0.156

NOTES:

1. Wall area per block or panel = 5.333 ft²
2. Forms are available as assembled (LOGIX PRO) or unassembled (or knock-down) form blocks (LOGIX KD Product drawings).
3. Concrete core thickness wider than 12" (305mm) are available using LOGIX Xtenders (See Logix Xtender Product drawing).
4. 6 1/4" [159mm] LOGIX Form shown.

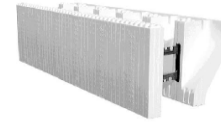
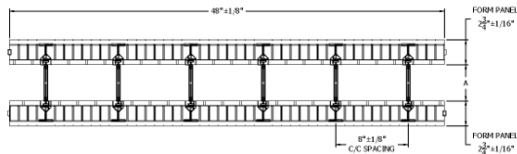
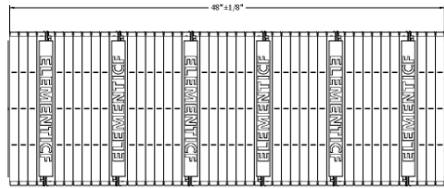

Figure 2a. Example Logix ICF Product Details



PLAN VIEW



SIDE ELEVATION

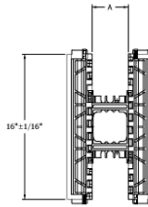

END VIEW

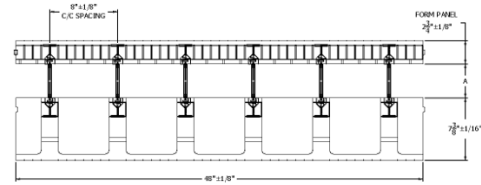

PLAN VIEW

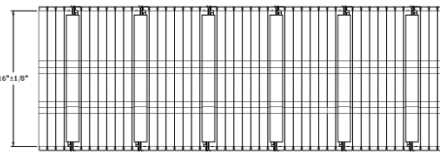

SIDE ELEVATION

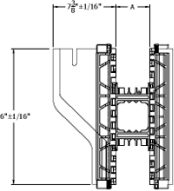

END VIEW

FORM SIZES	
	4" 6" 8" 10" 12"
A	4"+/-1/8" 6"+/-1/8" 8"+/-1/8" 10"+/-1/8" 12"+/-1/8"

NOTES:

1. DIMENSIONS APPLY TO ELEMENT PREFORM AND SITE-ASSEMBLED FORMS. FOR CLARITY ONLY SITE-ASSEMBLED STANDARD FORM SHOWN.

FORM SIZES	
	4" 6" 8" 10" 12"
A	4"+/-1/8" 6"+/-1/8" 8"+/-1/8" 10"+/-1/8" 12"+/-1/8"

NOTES:

1. DIMENSIONS APPLY TO ELEMENT PREFORM AND SITE-ASSEMBLED FORMS. FOR CLARITY ONLY SITE-ASSEMBLED BRICK LEDGE FORM SHOWN.

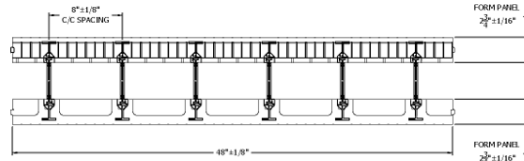

PLAN VIEW

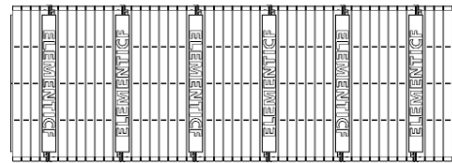

SIDE ELEVATION

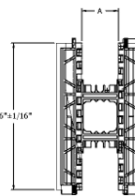

END VIEW

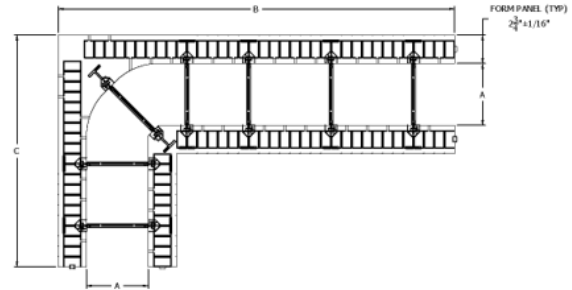

PLAN VIEW

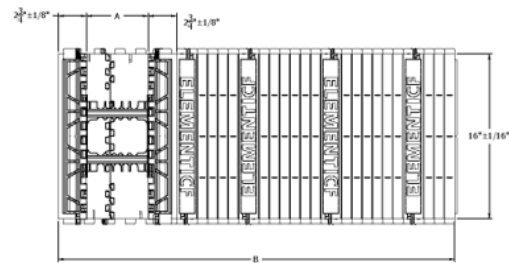

SIDE ELEVATION

FORM SIZES	
	4" 6" 8" 10" 12"
A	4"+/-1/8" 6"+/-1/8" 8"+/-1/8" 10"+/-1/8" 12"+/-1/8"

NOTES:

1. DIMENSIONS APPLY TO ELEMENT PREFORM AND SITE-ASSEMBLED FORMS. FOR CLARITY ONLY SITE-ASSEMBLED TAPER TOP FORM SHOWN.

FORM SIZES	
	4" 6" 8" 10" 12"
A	4"+/-1/8" 6"+/-1/8" 8"+/-1/8" 10"+/-1/8" 12"+/-1/8"
B	38.5"+/-1/16" 38.5"+/-1/16" 38.5"+/-1/16" 38.5"+/-1/16" 38.5"+/-1/16"
C	22.5"+/-1/16" 22.5"+/-1/16" 22.5"+/-1/16" 22.5"+/-1/16" 22.5"+/-1/16"

NOTES:

1. DIMENSIONS APPLY TO ELEMENT PREFORM AND SITE-ASSEMBLED FORMS. FOR CLARITY ONLY SITE-ASSEMBLED CORNER FORM SHOWN.

Figure 2b. Example of Element™ ICF Product Details



9.0 SUPPLEMENTAL CODES

9.1 2023 Florida Building Code:

Logix ICF and Element™ ICF as detailed in Sections 2.0 through 8.0 of QAI CER_{US}-1005 comply with the 2023 / 2020 Florida Building Code, Building and 2023/ 2020 Florida Building Code, Residential when installed in accordance with the applicable building codes and this report.

Logix ICF and Element™ ICF comply with Section 1620 High Velocity Hurricane Zones – Wind Loads of the 2023, 2020 Florida Building Code, Building when designed in accordance with Section 3 of this report.

Logix ICF and Element™ ICF comply with Section 1625 High Velocity Hurricane Zones – Load Tests of the 2023, 2020 Florida Building Code, Building when designed in accordance with Section 3 of this report.

Logix ICF and Element™ ICF comply with Section 1626 High Velocity Hurricane Zones – Impact Tests for Wind-Borne Debris of the 2023, 2020 Florida Building Code, Building when designed in accordance with Section 3 of this report.

Logix ICF and Element™ ICF EPS Foam Plastic Panels and Cross Ties comply with Section 26 Plastic of the 2023, 2020 Florida Building Code.

Logix ICF and Element™ ICF EPS Foam Plastic Panels and Cross Ties comply with Miami-Dade Checklist #0445 for the Approval of: Plastic and Foam Plastic

10.0 ELIGIBILITY OF REPORT

QAI's Code Evaluation Report complies with the 2021 / 2018 / 2015 IBC Section 104.11 *Alternative materials, design and methods of construction and equipment* subsection 104.11.1 *Research Reports*. Supporting data has been evaluated by QAI for compliance of the noted materials and assemblies to the applicable code by QAI, and *approved* source as detailed below.

The attached report has been reviewed by a QAI Registered Professional Engineer approved by the specific state Board of Professional Engineers noted on the specific P.E. seal(s).

Per section 1703 of the IBC, QAI is an independent third-party testing, inspection and certification agency accredited by the International Accreditation Service, Inc. (IAS) for this specific scope (see IAS PCA-118). QAI can confirm that based on its IAS accreditation it meets IBC Section 1703.1 on Independence, Section 1703.1.2 on Equipment and Section 1703.1 on Personnel.

This Evaluation report has been designed to meet the performance requirements of IBC Section 1703.4 and contains the required information to show the product, material or assembly meets the applicable code requirements.

The product is labeled per section IBC 1703 and subject to follow-up inspection per IBC 1703.6 using QAI IAS accredited ISO/IEC 17020 inspection program (see IAS AA-723).

For more information regarding QAI Laboratories, please visit www.qai.org.



The above is an example of the QAI registered Listing mark. The Listing mark may only be used by the Report Holder per the QAI service agreement on products defined in this report. The 'us' indicator in the 8 o'clock position indicates the product complies with the properties evaluated with limitations outlined in this report for use in the US market. A 'c' indicator in the 4 o'clock position indicates the product has been evaluated for use in the Canadian market.



CODE EVALUATION REPORT

LOGIX BRANDS, LTD.
CERus-1005
Revision: March 2024
Expiration: March 2027
Page 17 of 17

11.0 REFERENCED STANDARDS

ASTM E2634	<i>Standard Specification for Flat Wall Insulating Concrete Form.</i>
ASTM E84	<i>Standard Test for Surface Burning Characteristics of Building Materials.</i>
ASTM D2843	<i>Standard Test Method for Density of Smoke from the Burning or Decomposition of Plastics</i>
ASTM C578	<i>Standard Specification for Rigid, Cellular Polystyrene Thermal Insulation.</i>
ASTM D1929	<i>Standard Test Method for Determining Ignition temperature of Plastics.</i>
ASTM D635	<i>Test Method for Rate of Burning and/or Extent and Time of Building of Plastics in a Horizontal Position.</i>
ASTM C1396/C1396M	<i>Specification for Gypsum Board.</i>
NFPA 275	<i>Standard Method of Fire TSTS for the Evaluation of Thermal Barriers.</i>
ASTM E119	<i>Standard Test Methods for Fire Tests of Building Construction and Materials</i>
NFPA 285	<i>Standard Fire Test Method for the Evaluation of Fire Propagation Characteristics of Exterior Nonload-bearing Wall Assemblies Containing Combustible Compartments.</i>
UL 263	<i>Standard for Fire Tests of Building Construction and Materials.</i>
UL 1715	<i>Fire Test of Interior Finish Material</i>