

**BUILDING PRODUCTS LISTING PROGRAM**

**Class:** Factory Built Wall Assemblies

**Customer:** Panel-Built, Inc.  
**Location:** 302 Beasley Street, Blairsville, GA 30512

**Listing No.** B1052-1  
**Project No.** RJ1992-E  
**Effective Date:** July 25, 2012  
**Last Revised:** **No Revisions to Date**  
**Expires:** N/A

**Product:** Panel-Built 1 Hour Fire Rated Panels.

**Label:** **Product is marked with labels supplied by Panel-Built, Inc. The label includes the manufacturer's name, trademark, or other recognized symbol of identification, the product model designation, month and year of manufacture or equivalent traceability information, QAI logo with the 'US' and "C" identifier, and the statement "1-Hour Non-Load Bearing Fire Rated Assembly".**

Standards: ASTM E119 “Standard Test Methods for Fire Tests of Building Construction and Materials”.

CAN/ULC S101 “Standard Methods of Fire Endurance Tests of Building Construction”.

UBC “Fire Tests of Building Construction and Materials, “.

UL 263 “Standard for Fire Tests of Building Construction and Materials”.

NFPA 251 “Standard Methods of Tests of Fire Endurance of Building Construction and Materials”.

Ratings: The following outlines the 1 hour non-load bearing fire rated wall assembly listing by QAI:

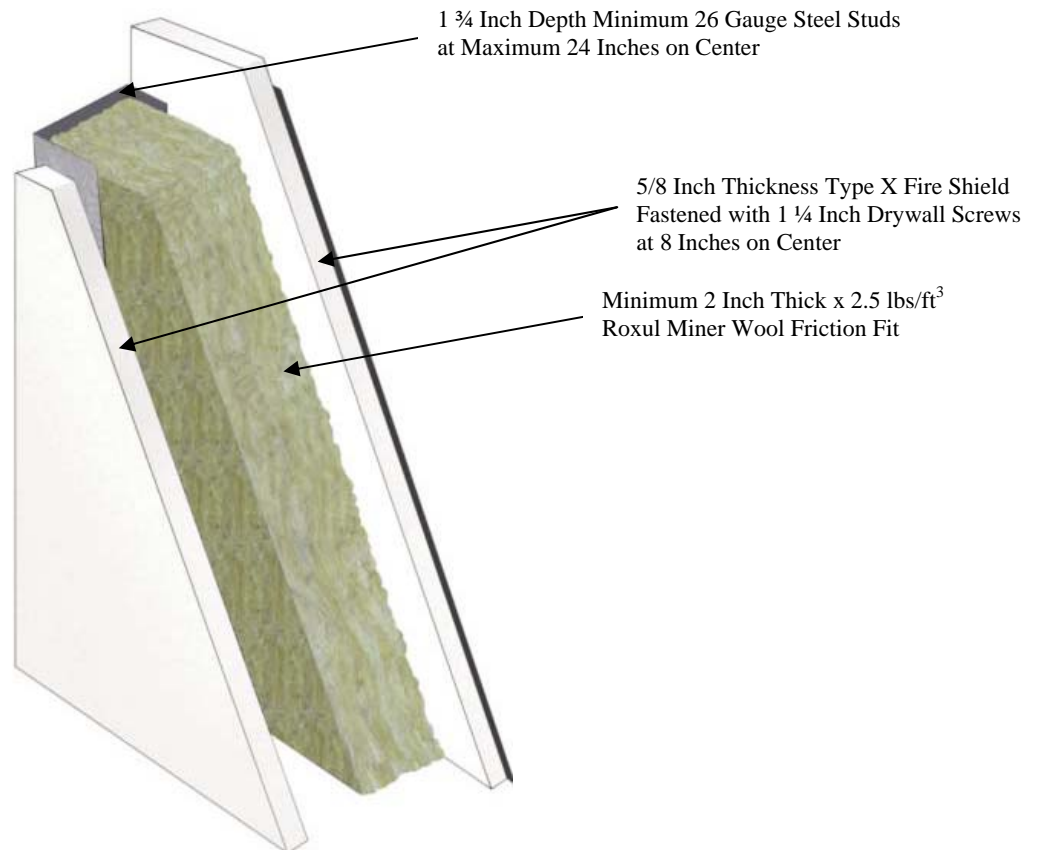

The joint details of Panel Built 1 Hour Fire Rated Walls are Shown Below.

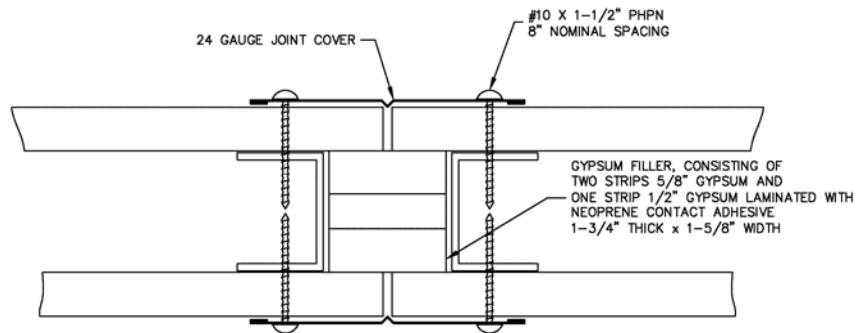

## ONE HOUR JOINT

**Note:**

**Final acceptance of the product in the intended application is to be determined by the authority having jurisdiction.**

**Product is to be installed in accordance with the manufacturer's published installation instructions by qualified installing personnel.**

\*\*\*