

QAI Design B1045-1a – STF Building Solutions Inc. - CAN/ULC S134
Maximum ≤ Heat Flux 35 kW/m² @ 3.5 m
Maximum Flame Spread < 5 m

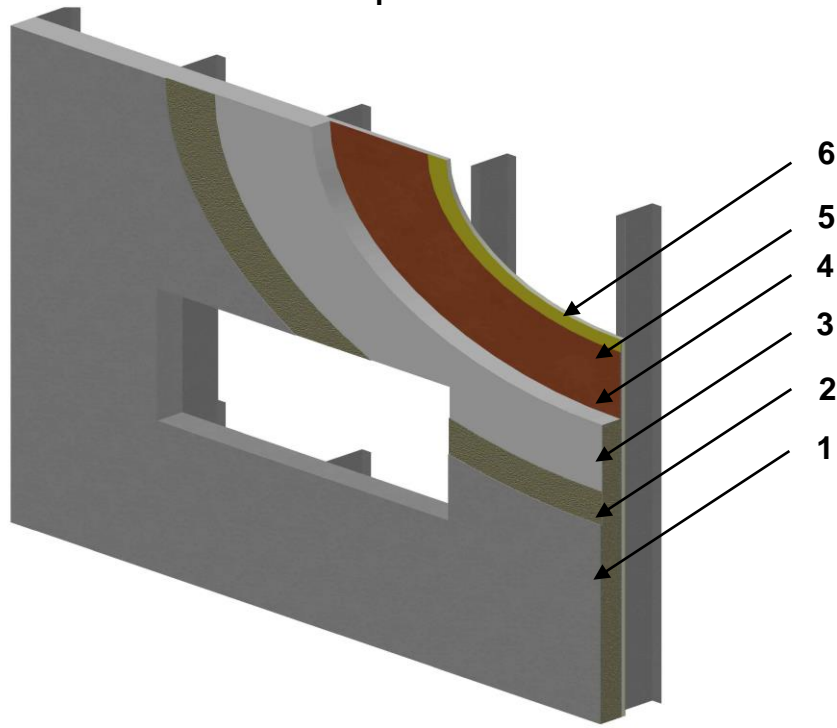

No.	COMPONENT	DESCRIPTION	STF Elite MA	STF Premier MW	STF Premier MA
System					
1	Finish Coat	Certified Manufacturer:	STF Building Solutions Inc.		
		Certified Product:	STF Architectural Classics or STF Genesis		
		Primer:	STF Prime		
2	Mesh	Minimum Weight:	150 g/m ² (4.5 oz/sq.yd.)		
		Type:	Treated fiberglass mesh embedded in base coat.		
		Installation:	Backwrapping the mesh and base coat are required on all joints or openings, or perimeter terminations, with a mesh strip of 240 mm (9 1/2") wide. Minimum 64 mm (5 1/2") overlap on all mesh edges.		
	Base Coat	Certified Manufacturer:	STF Building Solutions Inc.		
Certified Product:		STF Stratum NC– meets requirements of CAN/ULC S114			
Coating Thickness:		Minimum average thickness of 2.4 mm (100 mils)			
3	Insulation	Product:	Approved and Labeled - Type 1 EPS geometrically defined drainage insulation boards	ROXUL RXL 80	Approved and Labeled - Type 1 EPS flat insulation boards
		Density:	Maximum average density of 16 kg/m ³ (1.0 lb/ft ³)	128 kg/m ³ (8.0 lb/ft ³)	Maximum average density of 16 kg/m ³ (1.0 lb/ft ³)
		Flame Spread Index:	Maximum flame spread index of 250 when tested in accordance with CAN/ULC S102.2		
		Size:	610 mm x 1219 mm (24" x 48")	610mm x 1219 mm (24" x 48")	610 mm x 1219 mm (24" x 48")
		Thickness:	Maximum 50 mm (2")	50 mm – 100 mm (2" - 4")	Maximum 50 mm (2")
4	Adhesive/ Fastener Detail	Fasteners:	Mechanically fastened. Insulation boards with STF Fasteners spaced 400 mm (16") o.c. horizontally and 300 mm (12") o.c. vertically, drilled and screwed into the wall studs through the wall sheathing		
		Installation:	The channels facing the interior side of the panels. Offset vertical panel joints while maintaining channel alignment	Offset vertical panel joints	Offset vertical panel joints
5	Weather Resistive Barrier	Product:	Bituminous self-adhered barrier membranes, STF Elitestop CB, STF Elitestop PB or other STF-approved liquid applied (air and/or vapour) barriers depending on the wall system design requirements. Foam plastic water resistive barriers are not evaluated for use.		
		Installation:	Applied directly to the exterior sheathing		
6	Substrate	Type:	Code-approved substrates of brick, masonry, monolithic concrete walls, cementitious panels, glass-mat-surfaced gypsum sheathing board.		