



PUBLISHED: February 2024
EXPIRATION: February 2027

PRODUCT: CeDUR® SHAKES

REPORT HOLDER: Colorado Roofing Products, LLC
dba CeDUR

CONTACT DETAILS: 3590 Himalaya Road
Aurora, CO
80011 USA

CSI DIVISION: 07 00 00 - Thermal and Moisture Protection

CSI SECTION: 07 31 53 – Plastic Shakes

APPLICABLE CODES: 2021, 2018, 2015 International Building Code (IBC)
2021, 2018, 2015 International Residential Code (IRC)
2022, 2019 California Building Code, Title 24, Part 2 (CBC)
2022, 2019 California Residential Code, Title 24 Part 2.5 (CRC)
2023, 2020 Florida Building Code, Building (FBC)
2023, 2020 Florida Building Code, Residential (FRC)

EVALUATED: Weather Resistance
Wind Resistance
Roof Fire-Classification
Hail-Impact Resistance



www.qai.org

QAI LABORATORIES

LOS ANGELES | TULSA | MIAMI | TORONTO | VANCOUVER | SEOUL | SHANGHAI



CODE EVALUATION REPORT

1.0 APPROVED FOR FOLLOWING:

APPROVED TYPES OF CONSTRUCTION:	Type I-V/ AB
APPROVED USE:	Roof coverings for use in Class A fire-classified assemblies.
APPROVED INSTALLATIONS:	New and existing roofs where existing roof is removed, roof fire-classified assemblies including areas prone to hail impact as detailed in Section 4 of this report.

2.0 DESCRIPTION:

2.1 General:

CeDUR® synthetic roofing products are composite polymeric based roof coverings including accessories molded from proprietary formulations to create the look of cedar shakes for use on slopes $\geq 4:12$. CeDUR® products are a durable exterior roof covering available in various colors. When installed in accordance with Section 4.4 and Table 3 of this report, CeDUR® products provide Class A roof-fire assemblies determined in accordance with Section 1505.1 of the 2021 / 2018 / 2015 IBC and Section R902.1 of the 2021 / 2018 / 2015 IRC with Class 4 resistance to hail and impact per UL 2218.

CeDUR® synthetic roofing products have a spontaneous ignition temperature $\geq 650^{\circ}\text{F}$ (343°C) when tested to ASTM D1929 and are classified as CC2 when tested to ASTM D635.

See Table 1 below for recognized models of CeDUR® products. See Section 2.2 of this report for applications of the described products. See Figure 2 in Section 9.1 of this report for drawings of the products listed in Table 1.

Table 1. CeDUR® SYNTHETIC ROOF COVERING PRODUCT DIMENSIONS

PRODUCT	LENGTH		WIDTH		INSTALLED EXPOSURE		INSTALLED WEIGHT	
	inches	mm	inches	mm	inches	mm	lbs/ft ²	kg/m ²
CeDUR®	23.5	597	5-1/4 7-1/4 12-1/4	133 184 311	10	254	1.7	8.30

CeDUR® products are available with starter tiles and preformed hip/ridge cap accessories.

CeDUR® products comply for use as roof coverings per the 2022 / 2019 California Building Code and 2022 / 2019 California Residential Code including use in *Fire Hazard Severity Zones*. See Section 10 of this report for further details.

CeDUR® products comply for use as roof coverings per the 2023 / 2020 Florida Building Code (FBC), and 2023 / 2020 Florida Building Code, Residential (FRC) excluding use in areas defined as high-velocity hurricane zones. See Section 10 of this report for further details.



CODE EVALUATION REPORT

CeDUR® SHAKES
CERus-1025
Issued: February 2024
Expiration: February 2027
Page 2 of 10

2.2 PRODUCTS

2.2.1 CEDUR®:

CeDUR® products are supplied with dimensions of 23.5 inches (597 mm) x 5.25 inches (133 mm), 7.25 inches (184 mm), or 12.25 inches (311 mm) with an installed exposure of 10 inches (254 mm). CeDUR® products are of 1/8-inch (3.2 mm) head thickness, and 3/4-inch (19 mm) butt thickness. CeDUR® have weights of 0.7 lbs (0.3 kg) (5.25-inch width), 0.9 lbs (0.4 kg) (7.25-inch width) and 1.8 lbs (0.8 kg) (12.25-inch width) per shake. CeDUR® products include designated fastener locators across the width of panel as shown in Figure 2 of this report. CeDUR® are molded to create a wood shake style finish. CeDUR® products are available in the following color options: Live Oak, Shiloh, Golden Cedar and Walden.

3.0 DESIGN:

CeDUR® synthetic roofing products are roof coverings for installation over code complying roof sheathings and underlayment. CeDUR® synthetic roofing products are intended for use as the finished roof covering on new and over existing construction where existing roof coverings have been removed in accordance with Section 4.2 and 4.3 of this report as applicable.

Use of CeDUR® synthetic roofing products do not require professional design when installed in areas of maximum 130 mph (209 km/h) basic design wind speed (V), or ultimate (maximum) design wind speed (V_{Ult}) on structures of maximum 40 ft (12.2) height Exposure Category B when following standard installation methods outlined in Section 4.1 to 4.4 of this report. Where installed in accordance with Table 2 of this report, CeDUR® synthetic roofing is limited to applications to maximum allowable uplift pressures of 101 psf (4.8 kPa). Use of CeDUR® synthetic roofing products in applications of wind resistance greater than those described above are outside the scope of this report and requires approval by the authority having jurisdiction.

When used in applications requiring roof fire classified assemblies, installation shall be in accordance with Section 4.4 and Table 3 of this report.

When installed in areas defined as hail-prone, installation shall be in accordance with Section 4.6 Table 4 of this report for the hail-impact classification levels described.

4.0 INSTALLATIONS:

4.1 General:

Installation of CeDUR® synthetic roofing products must comply with the manufacturer's published installation instructions, this report, and the applicable code(s). Where differences are found, this report and the applicable building code shall be followed.

CeDUR® synthetic roofing products require installation over solid wood structural sheathing of 15/32-inch (12 mm) or lumber of nominal 1-inch (25 mm) complying with the applicable code. Attachment of the sheathing to underlying framing elements is outside the scope of this report and shall be sufficient to resist service loads. The CeDUR® roofing products are intended for installation onto minimum 4:12 (33%) and maximum 21:12 (175%) roof slopes.

Flashing, counterflashing, and valley flashing shall be sheet metal complying with the applicable code, where the sheet metal is G90 galvanized of minimum 0.0179 inches (0.455 mm) uncoated thickness. Valley flashing shall be a minimum 15 inches (381 mm) wide sheet metal of minimum 0.0179 inches (0.455 mm) uncoated thickness. Flashing including fasteners shall not be in contact with dissimilar metals to avoid corrosion. Flashing shall prevent moisture from entering the wall and roof in



CODE EVALUATION REPORT

CeDUR® SHAKES
CERus-1025
Issued: February 2024
Expiration: February 2027
Page 3 of 10

accordance with Section 1503.2 of the 2021 / 2018 / 2015 IBC and Section R903.2 of the 2021 / 2018 / 2015 IRC.

While not required, drip edge flashings and rake edge flashings are recommended, installed with good roofing practice.

4.1.1 Special Inspection:

IBC: Installation in areas of maximum V_{Ult} of 130 mph (209 km/hr), maximum mean roof height of 40 ft (12.2 m) and Exposure Category B do not require special inspection.

Special inspection including periodic special inspection for wind resistance are required for buildings constructed in the following areas:

1. Wind Exposure Category B, where V_{Ult} is \geq 150 mph (241 km/hr).
2. Wind Exposure Category C or D, where V_{Ult} is \geq 140 mph (225 km/hr).

Special inspection is to confirm installation is in conformance with Table 2 of this report, including competent bonding of the noted approved adhesive at CeDUR® head lap ends.

4.1.1 Underlayment:

Underlayment must comply with and be installed in accordance with the applicable code and the manufacturer's published installation instructions. For fire-classified roof assemblies underlayment shall be installed in accordance with Section 4.4 and Table 3 of this report.

In areas where there is potential for or has been a history of ice forming along eaves causing the backup of water an ice barrier is required. The ice barrier may consist of:

- a) Two layers of ASTM D226 Type I, ASTM D4869 Type I or ASTM D6757 underlayment cemented together or
- b) A self-adhering polymer modified bitumen sheet complying to ASTM D1970.

Alternate ice barriers are outside the scope of this report but may be used where approved by the authority having jurisdiction.

The ice barrier shall be used as an alternative to the normal underlayment, extending from the lowest edges of all roof surfaces to a point at least 24 inches (610 mm) inside the exterior wall line of the structure. Following, the standard underlayment shall be lapped over the ice barrier and shall overlap a minimum of 4 inches (102 mm). Attachment and overlapping of the ice barrier to underlayment are outside the scope of this report and is to be in accordance with the applicable code and the ice barrier manufacturer's published installation instructions.

4.2 New Construction:

4.2.1 Slopes > 6:12: Starter tiles are installed with a 3/4-inch (19 mm) to 1-inch (25 mm) overhang at the gable end fascia board and at eaves fascia boards across the roof deck. Subsequent CeDUR® shakes are installed by varying product widths during installation at the exposures described in Table 1 of this report, with tile joints staggered between alternating rows and a 1/4-inch (6 mm) to 3/8-inch (10 mm) keyway spacing between adjacent tiles. CeDUR® products require installation with corrosion resistance fasteners installed at through designated fastener locations. Two (2) fasteners are required for 5-1/4-inch (133 mm) and 7-1/4-inch (184 mm) product widths, and three (3) fasteners are required for 12-1/4-inch (311 mm) product widths. The following outlines approved fastener types:



CODE EVALUATION REPORT

CeDUR® SHAKES
CERus-1025
Issued: February 2024
Expiration: February 2027
Page 4 of 10

For areas of maximum V_{ult} of 130 mph (209 km/hr), maximum mean roof height of 40 ft (12.2 m) and Exposure Category B, approved fasteners include:

1. 11-Gauge x 5/16-inch (8 mm) diameter head ring shank roofing nails of minimum 1-3/4-inch (44 mm) length.
2. 16-Gauge x 15/16-inch (24 mm) crown x 1-7/8-inch (48 mm) leg length staples.
3. 5/16-inch (8 mm) diameter head coarse thread #6 wood screws of minimum 1-3/4-inch (44 mm) length.

Installations for applications up to 101 psf (4.8 kPa) wind uplift resistance, are to follow Table 2 of this report.

Upon reaching the roof peak, the last row of tiles are trimmed flush with the peak to accommodate the ridge and hip caps. All penetrations and chimneys are to be flashed in accordance with the appropriate code to prevent water ingress with compatible sheet metal complying with Section 4.1 of this report.

Ridge caps, hip caps and valleys are to be installed in accordance with the manufacturer's installation instructions and the applicable codes.

4.2.2 4:12 < Slopes ≤ 6:12: CeDUR® Starter tiles are installed with a 3/4-inch (19 mm) to 1-inch (25 mm) overhang at the gable end fascia board and at eaves fascia boards across the roof deck. Prior to installation of the following CeDUR® course, an additional interlayment of minimum 18-inches (457 mm) is installed over the starter tile, extending up-slope 9-inches (229 mm) onto the sheathing. The second course of CeDUR® is installed at 10-inch (254 mm) exposure, following 18-inch (457 mm) interlayment is applied at the 10-inch (254 mm) line on the CeDUR® shake, extending up-slope onto the sheathing. This process is repeated until roof peak, with installation in accordance with Section 4.2.1 for tile placement, keyway gaps and fastener installation.

4.3 Reroofing Applications:

CeDUR® products are not intended for installation over existing roof systems. Existing roof coverings and underlayment are to be removed, and roof sheathing and penetrations as appropriate are to be inspected to ensure the roof structure is free of rot and damage prior to installation of the CeDUR® products. All past existing roof coverings shall be completely removed, following all installation conditions noted in Section 4.1 and 4.2 shall apply.

4.4. Roof Fire Classified Assemblies:

CeDUR® products comply for use as Class A roof-assemblies per 2021 / 2018 / 2015 IBC Section 1505.1 and 2021 / 2018 / 2015 IRC Section R902.1 as outlined in Table 3 of this report. Installation including maximum roof slope is to be in accordance with Section 8.2 Table 3 of this report.

4.5 Hail-Impact Resistant Assemblies:

CeDUR® products are Class IV impact resistance rated evaluated following UL 2218. Installation is to be in accordance with Section 8.3 Table 4 of this report.



CODE EVALUATION REPORT

5.0 LIMITATIONS

- Installation of CeDUR® products are to comply with the applicable codes, this report and the manufacturer's installation instructions. Where differences are found, the applicable code and this report govern.
- CeDUR® products are intended for use on roof slopes $\geq 4:12$ (33%) to $\leq 21:12$ (175%).
- CeDUR® products are approved for use in areas where maximum wind speeds and pressures are as outlined in Section 3.0 and Section 8.1 Table 2 of this report. Use in applications greater than those stated require approval by a registered design professional and approval by the authority having jurisdiction.
- CeDUR® roof coverings acting as wind-resisting components in *V* areas as specified in per Section 1705.12 of the 2021 /2018 / 2015 IBC, require *Special Inspection* including periodic inspection, to confirm ongoing connection of components as outlined in Table 2 of this report.
- CeDUR® products used in Class A roof-assemblies are to be installed in accordance with Sections 4.4 and 8.2 Table 3 of this report.
- CeDUR® products used in hail-prone areas are to be installed in accordance with Sections 4.5 and 8.3, Table 4 of this report.
- CeDUR® products are manufactured in Aurora, CO with inspections by QAI Laboratories.

6.0 SUPPORTING INFORMATION:

The following data has been evaluated for CeDUR® products:

- Data for use in roof fire classified assemblies determined in accordance with ASTM E108.
- Data outlining $< 10\%$ loss of tensile strength after aging to ASTM G155 for 2000 hours.
- Data outlining CC2 rate of burning determined in accordance with ASTM D635.
- Data outlining spontaneous ignition temperature $> 650^{\circ}\text{F}$ (343°C) determined in accordance with ASTM D1929.
- Data for Wind Uplift evaluated in accordance with UL 580 and TAS 125.
- Data for outlining Class IV impact resistance per UL 2218.
- Data outlining compliance with ICC-ES AC07.



CODE EVALUATION REPORT

7.0 MARKINGS:

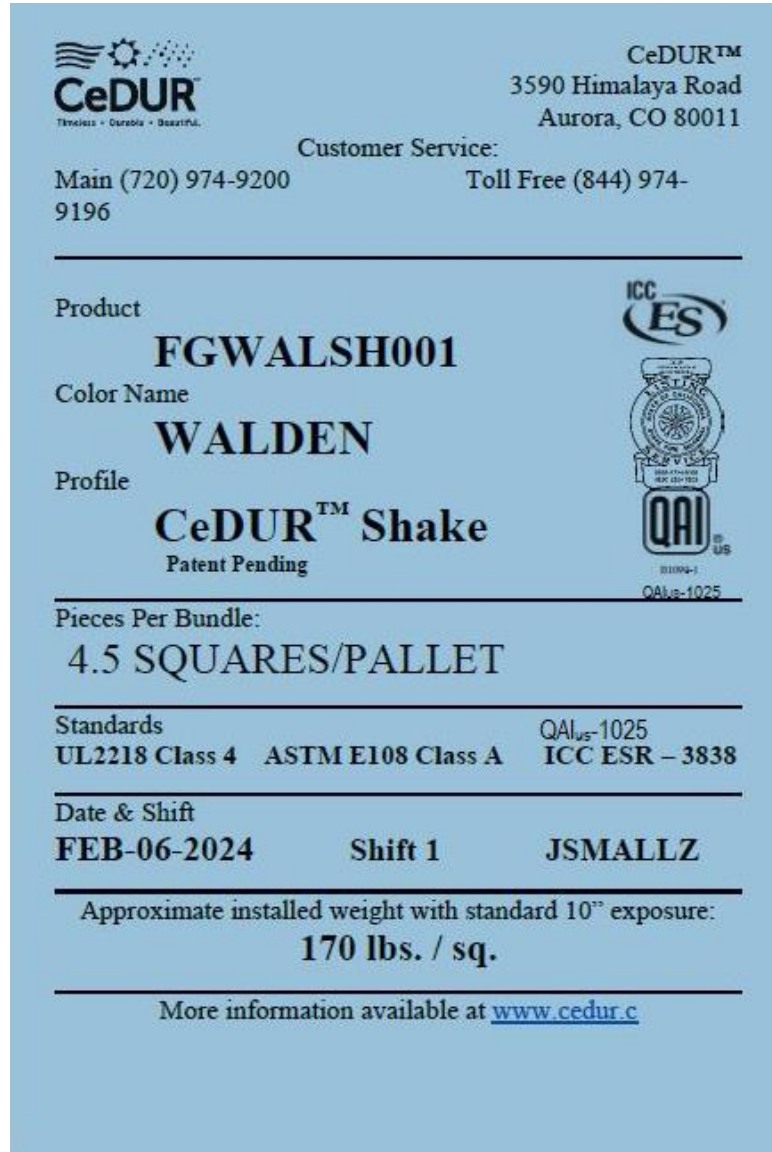

Figure 1a. Example of CeDUR® Product Labels



CODE EVALUATION REPORT

8.0 RATINGS:

8.1 Wind Uplift Resistance:

Table 2 – Maximum Allowable Wind Uplift Pressures on Roofing Panels

Product	Substrate ¹	Installation	Allowable Wind Uplift ² psf (kPa)
CeDUR®	Minimum 15/32-inch (12 mm) Exposure 1 plywood over 24-inch (610 mm) spaced framing.	Maximum installed exposure of 10-inches (254 mm). 5-1/4-inch (133 mm) and 7-1/4-inch (184 mm) width products are installed with two (2) 1-3/4-inch (44 mm) length ring-shank nails at designated fastener locations. 12-1/4-inch (311 mm) width are installed with three (3) 1-3/4-inch (44 mm) length ring-shank nails at designated fastener locations. After anchoring, GE Silicone II adhesive is applied at center of tile for the 5-1/4-inch (133 mm) and 7-1/4-inch (184 mm) width products, and at 1- 1-3/4-inches (44 mm) from each tile edge on 12-1/4-inch (311 mm) products to bond subsequent CeDUR™ courses.	101 (4.8)

Note 1: Attachment of sheathing to underlying framing members is outside the scope of this report, and shall be sufficient to resist uplift forces noted:

Note 2: Maximum uplift pressure was determined in accordance with method UL 580 / TAS 125 with a factor of safety 2.0 applied to ultimate pressure achieved.

Note 3: See Section 4.1.1 where *Special Inspection* including periodic inspection of the above installation is required.

8.2 Roof Fire Classified Assemblies:

Table 3 – Roof Fire Classified Assemblies

System	Substrate	Approved Underlayment	Approved Roof Coverings	Installation Guidelines	Maximum Slope	Class
New Construction Or Reroof when existing roof is removed ¹	Minimum 15/32-inch-thickness plywood	1 layer of ASTM D226 Type II asphalt felt installed over the sheathing with offset joints minimum 6-inches (152 mm).	CeDUR™ Shakes	See Sections 2.2, 4.1, 4.2, 4.3	Unlimited	A

Note 1: Installation of the CeDUR® products requires complete removal of existing roof coverings and underlayment and inspection prior to installation in accordance with Section 4.3 of this report.

8.3 Hail Impact Resistant Assemblies:

Table 4 – Impact Rated Assemblies

Substrate	Approved Underlayment	Approved Roof Coverings	Installation Guidelines	Hail-Impact Classification ¹
Minimum 15/32-inch-thick plywood	Unrestricted	CeDUR™ Shakes	See Sections 2.2, 4.1, 4.2 and 4.3	Class IV

Note 1: Hail-impact classification determined in accordance with UL 2218.

9.0 PRODUCT DETAILS:

9.1 Profile Drawings

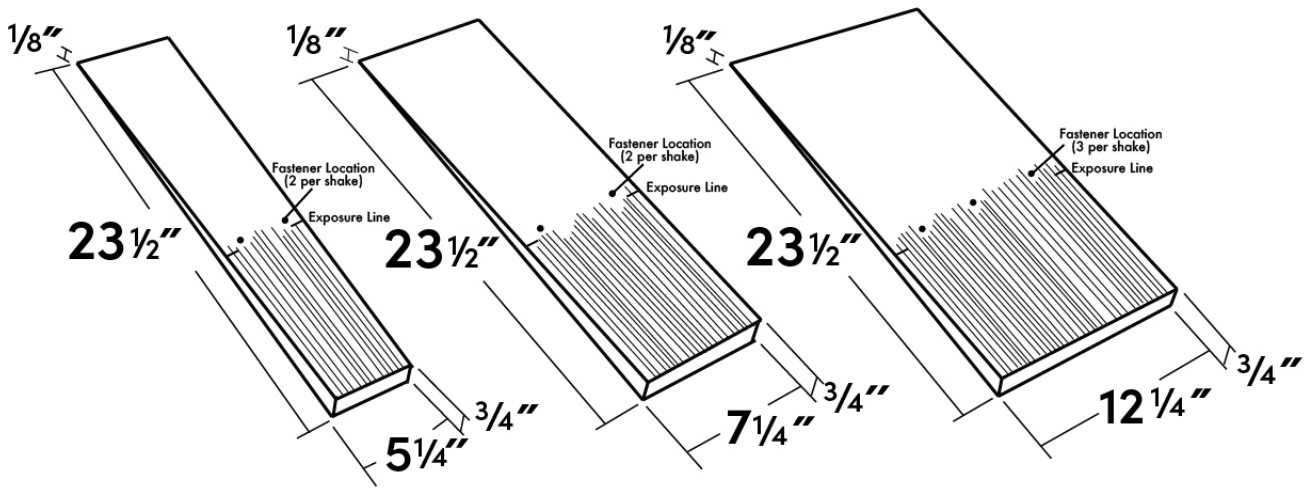

Figure 2. Product Drawings

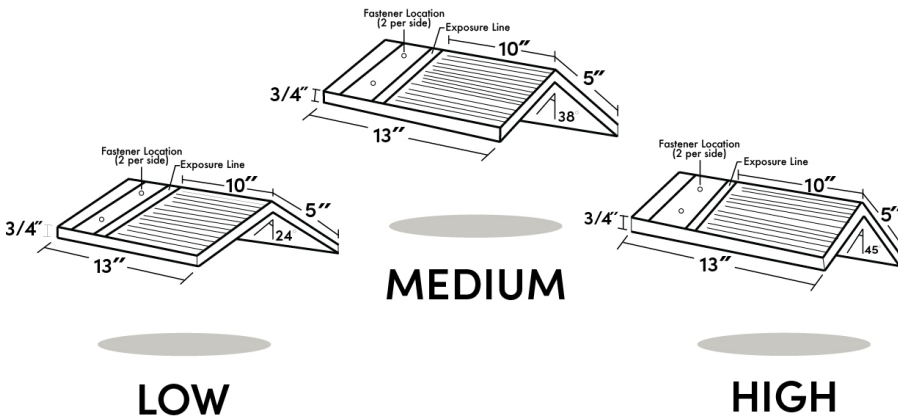

Figure 3. Hip and Ridge Cap Drawings

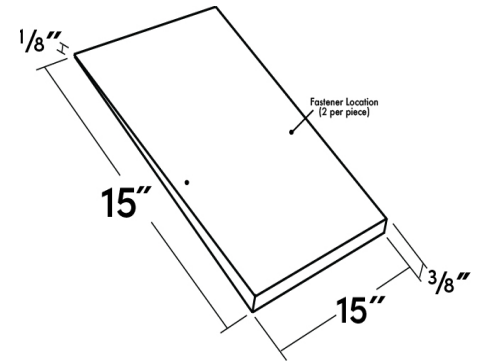

Figure 4. Starter Tile



CODE EVALUATION REPORT

10.0 SUPPLEMENTAL CODES

10.1 2023 / 2020 Florida Building Code:

CeDUR™ products as detailed in Sections 2.0 through 9.0 of QAI CER_{US}-1025 comply with the 2023 / 2020 Florida Building Code (FBC) and 2023 / 2020 Florida Building Code, Residential (FRC) when installed in accordance with the applicable building codes and this report for use in areas not defined as high velocity hurricane zones (HVHZ) for applications as outlined in this report.

10.2 2024 / 2021 California Building Code:

CeDUR™ products as detailed in Sections 2.0 through 9.0 of QAI CER_{US}-1025 comply with the 2022 / 2019 California Building Code and 2022 / 2019 California Residential Code when installed in accordance with the applicable building codes and this report.

CeDUR™ products installed in accordance with Section 4.4 and Table 3 of this report, provide Class A fire classification and comply for use in *Fire Hazard Severity Zones* as outlined in Section 705A of the 2022 / 2019 CBC and Section R337.5 of the 2022 / 2019 CRC.

11.0 ELIGIBILITY OF REPORT

QAI's Code Evaluation Report complies with the 2021 / 2018 / 2015 IBC Section 104.11 *Alternative materials, design and methods of construction and equipment* Subsection 103.11.1 *Research Reports*. Supporting data has been evaluated by QAI for compliance of the noted materials and assemblies to the applicable code by QAI, an *approved* source as detailed below.

The attached report has been reviewed by a QAI Registered Professional Engineer approved by the specific state Board of Professional Engineers noted on the specific P.E. seal(s) where applied.

Per section 1703 of the IBC, QAI is an independent third-party testing, inspection and certification agency accredited by the International Accreditation Service, Inc. (IAS) for this specific scope (see IAS PCA-118). QAI can confirm that based on its IAS accreditation it meets IBC Section 1703.1 on Independence, Section 1703.1.2 on Equipment and Section 1703.1 on Personnel.

This Evaluation report has been designed to meet the performance requirements of IBC Section 1703.4 and contains the required information to show the product, material or assembly meets the applicable code requirements.

The product is labeled per section IBC 1703 and subject to follow-up inspection per IBC 1703.6 using QAI IAS accredited ISO 17020 inspection program (see IAS AA-723).

For more information regarding QAI Laboratories, please visit www.qai.org.



The above is an example of the QAI registered Listing mark. The Listing mark may only be used by the Report Holder per the QAI service agreement on products defined in this report. The 'us' indicator in the 8 o'clock position indicates the product complies with the properties evaluated with limitations outlined in this report for use in the US market. A 'c' indicator in the 4 o'clock position indicates the product has been evaluated for use in the Canadian market.

11.0 REFERENCED STANDARDS

ASTM E108 *Standard Test Methods for Fire Tests of Roof Coverings*.

ASTM G155 *Standard Practice for Operating Xenon Arc Light Apparatus for Exposure of Non-Metallic Materials*.

ASTM D635 *Test Method for Rate of Burning and/or Extent and Time of Burning of Plastics in a Horizontal Position*.

ASTM D1929 *Test Method for Determining Ignition Temperature of Plastics*.

UL 580 *Safety Testing for Uplift Resistance of Roof Assemblies*.

TAS 125 *Standard Requirements for Metal Roofing Systems*.

UL 2218 *Standard for Safety Impact Resistance of prepared Roof Covering Materials*.

ICC-ES AC07 *Acceptance Criteria for Special Roofing Systems*.