

**QAI Design B1096-2c – Norbec Architectural – NOROC-L Mineral Wool Insulated Panel  
 CAN/ULC-S101/ASTM E119 – 90-Minute Non-Load Bearing Fire-Resistance Rated Floor/Ceiling Assembly**

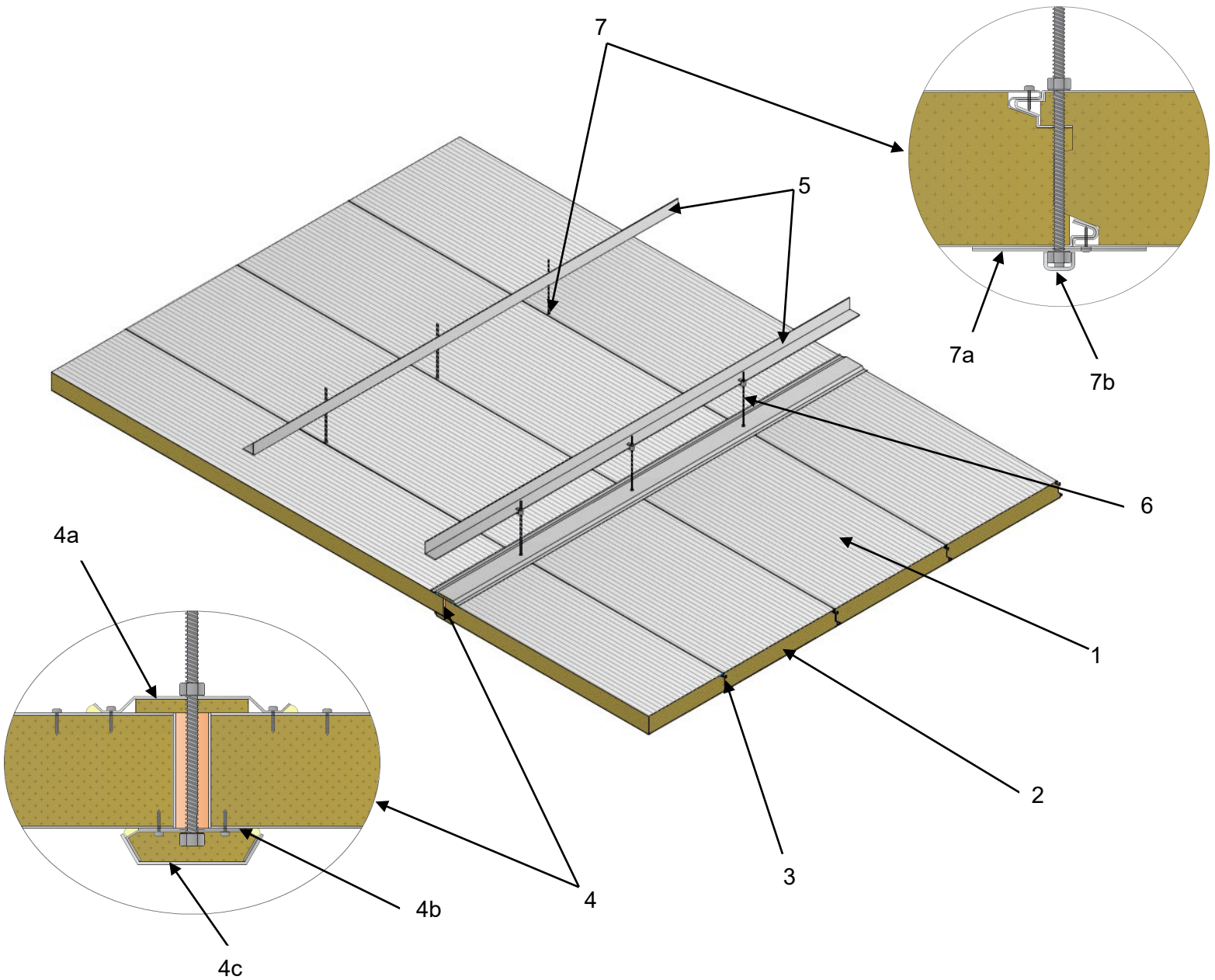

| No. | COMPONENT       | DESCRIPTION          |   |
|-----|-----------------|----------------------|---|
| 1   | NOROC-L Panels  | Manufacturer:        | Norbec Architectural Inc.                         |
|     |                 | Approved Product(s): | NOROC-L Mineral Wool Core Insulated Metal Panels. |
|     |                 | Facers               | Minimum 0.454 mm (26 Gauge) steel.                |
|     |                 | Minimum Thickness    | 152 mm (6").                                      |
| 2   | Core Insulation | Material             | Non-combustible mineral wool.                     |
|     |                 | Minimum Thickness    | 152 mm (6").                                      |
|     |                 | Minimum Density      | 8.5 lbs/ft3 (136 kg/m3).                          |

| No. | COMPONENT                     | DESCRIPTION   |  |
|-----|-------------------------------|---|--|
| 3   | Panel Interlocking Joint      | Description   | Male-Female Interlocking Joint connection along panel edge.  |
|     |                               | Maximum Joint Width   | 8 mm (5/16").  |
|     |                               | Installation:   | Polyurethane Insulating foam applied 305 mm (12") along each end of the female panel joint.<br><br>Panels are interlocked and fastened 38 mm (1-1/2") from the panel joint using #8 19 mm (3/4") self-drilling screws, spaced 455 mm (18") on the top side of the assembly and spaced 915 mm (36") along the bottom side of the panel.   |
|     |                               | Sealant:  | Polyurethane Insulating foam is applied 305 mm (12") along each end of the female panel joint.<br><br>The top side panel joints are caulked with silicone sealant.   |
| 4   | Panel Edge-to-Edge Joint      | Description   | Panel Edge-to-Edge Joint supported by galvanized steel trims and connected with threaded zinc rods.  |
|     |                               | Maximum Joint Width:  | 16 mm (5/8").  |
|     |                               | Installation:   | The top side of the panel joint is secured with a 145 mm (5-11/16") wide galvanized steel trim (4a) filled with a layer of mineral fiber insulation attached using two #8 19 mm (3/4") self-drilling screws spaced every 610 mm (24") and fastened at threaded rods using 9.5 mm (3/8") -16 Grade 5 zinc hexagonal nuts.<br><br>The interior side of the panel joint is secured using a 90 mm (3-1/2") wide galvanized steel suspension support (4b) fastened using two #8 19 mm (3/4") self-drilling screws spaced every 810 mm (32") and fastened with the threaded zinc rods using 9.5 mm (3/8") -16 Grade 5 zinc hexagonal nuts. The steel support is covered by a pre-painted finished trim (4c) riveted with 3.2 mm Ø x 6.4 mm (1/8" Ø x 1/4") pop-rivets, and the space between these components is filled with mineral fiber insulation. |
|     |                               | Sealant:  | Panel joint is filled with flame-resistant polyurethane foam sealant.<br><br>A silicone bead is applied along the edges of the steel trim on both top and bottom faces of the panel.   |
| 5   | Support Structure             | Details:<br><br>Panels are mechanically connected to structural members. Support structure is to be engineered to support intended design load as determined by Design Professional, or the Authority Having Jurisdiction. See spacing requirements of the support rods in Section (6). |  |
| 6   | Support Rods                  | Description   | 9.5 mm (3/8") zinc threaded hanger rods.   |
|     |                               | Spacing (Edge-to-Edge Joint)  | Three rods located 1980 mm (78") from the panel edge and spaced every 1080 mm (42-1/2") at panel interlocking joints   |
|     |                               | Spacing (Suspension Disks)  | Three rods located 1900 mm (75") from the panel edge and spaced every 1080 mm (42-1/2") at panel interlocking joints.  |
| 7   | Panel Suspension Disk Support | Description   | Steel suspension disk supports connected to interior face of panels through threaded zinc rods located along panel joints.   |
|     |                               | Installation:   | 9.5 mm (3/8") zinc flat washers and 9.5 mm (3/8") -16 Grade 5 zinc hexagonal nuts are fastened to the threaded rod at the exterior surface of the panel.<br><br>127 mm (5") diameter 0.454 mm (26 Gauge) white galvanized steel and 1.214 mm (18 Gauge) galvanized steel suspension discs (7a) are fastened to the interior surface panel at each threaded rod using 9.5 mm (3/8") -16 Grade 5 zinc hexagonal nuts covered with a friction-fit white vinyl hex cap (7b).   |

Note: Resistance of this assembly to service loads, including pressure and seismic forces, is outside the scope of QAI's listing.