

**QAI Design B1096-2 – Norbec NOROC Mineral Wool Insulated Wall Panel Assembly
CAN/ULC-S101/ASTM E119 - 3 Hour Non-Load Bearing Fire-Resistance-Rated Wall Assembly**

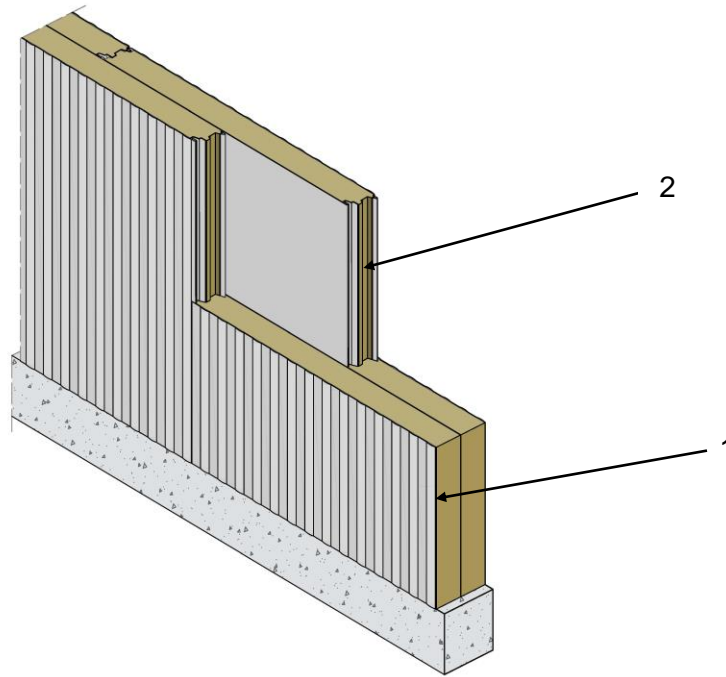

No.	COMPONENT	DESCRIPTION	
1	Norbec Mineral Wool Panel	Manufacturer:	Norbec Architectural Inc.
		Product Name:	NOROC Mineral Wool Steel Skinned Panel
		Minimum Thickness:	100 mm (4 inch) mineral wool core, laminated to 0.457 mm (26 Gauge) Steel Skins
		Application:	Adjacent panels joined per manufacturers installation instructions. Second panel layer has vertical joints offset.
		Connection:	Panels anchored top and bottom of panel with 1.519 mm (16 Gauge) steel U channel with no. 8 x 19 mm (3/4 in.) self-drilling pan head screws spaced 305 mm (12 in.) on center.
		Joints:	Butyl sealant is factory applied at panel female joints. Optional: Exterior joints sealed with silicone sealant.
2	Norbec Mineral Wool Panel	Manufacturer:	Norbec Architectural Inc.
		Product Name:	NOROC Mineral Wool Steel Skinned Panel
		Minimum Thickness:	100 mm (4 inch) mineral wool core, laminated to 0.457 mm (26 Gauge) Steel Skins
		Application:	Adjacent panels joined per manufacturers installation instructions. Second panel layer has vertical joints offset.
		Connection:	Panels anchored top and bottom of panel with 1.519 mm (16 Gauge) steel U channel with no. 8 x 19 mm (3/4 in.) self-drilling pan head screws spaced 305 mm (12 in.) on center.
		Joints:	Butyl sealant is factory applied at panel female joints. Optional: Exterior joints sealed with silicone sealant.