

QAI Design B1123-1a – HercuTech Inc. –ASTM E119  
HercuWall® Series 8 Panel System  
1 Hour Fire-Resistance Rated Load-Bearing Wall Assembly

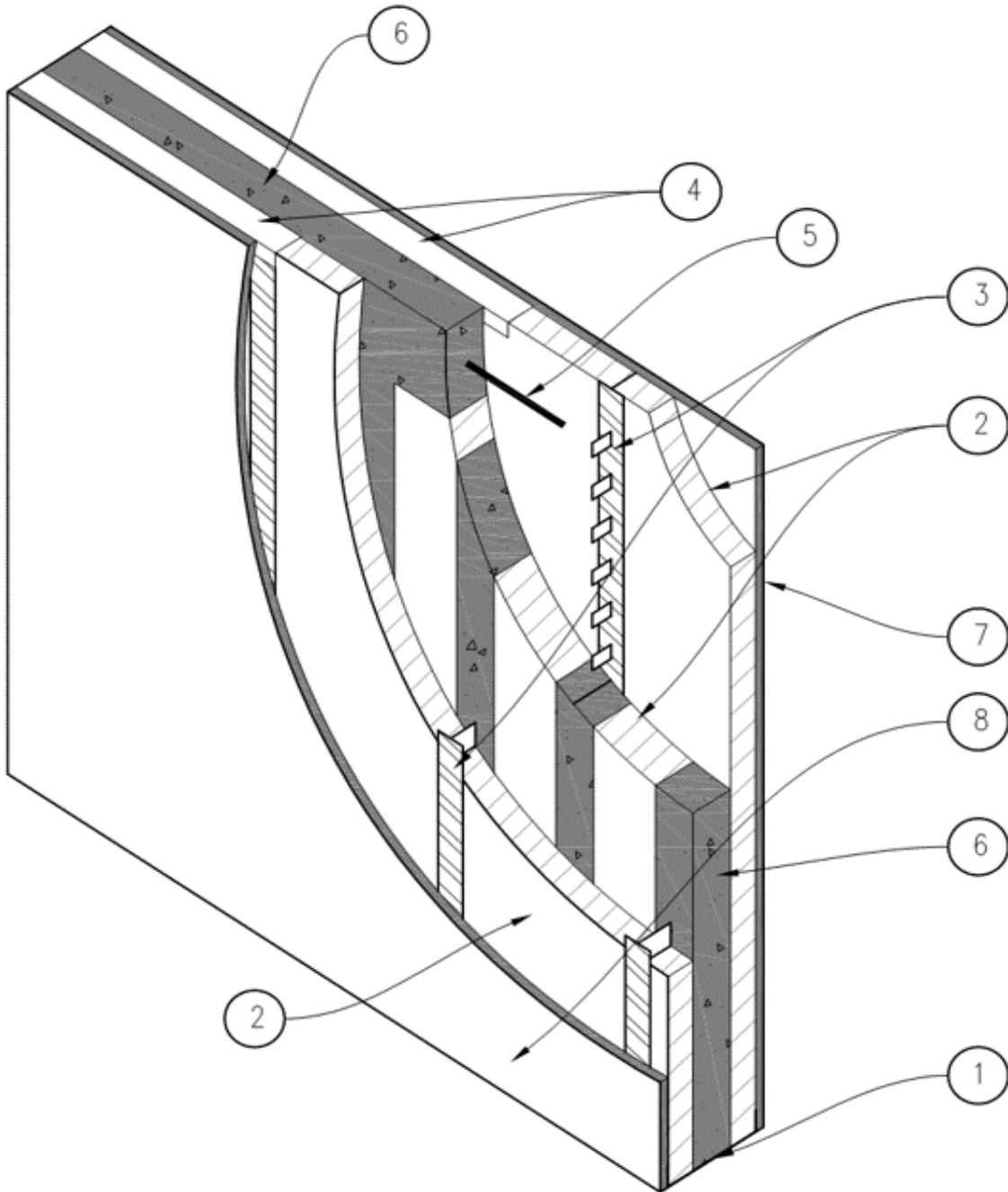

Item	COMPONENT	DESCRIPTION	
1	Bottom Track	Manufacturer:	HercuTech Inc.
		Minimum Size:	24 gauge (0.022 inches) (0.55 mm) thickness. 8 Inches (203 mm) depth.
		Installation:	Caulked and pinned to the foundation or underlying wall per manufacturers specifications.
2	HercuWall® Panel	Manufacturer:	HercuTech Inc.
		Approved Types:	Type S, Type SW, Type A products of Type II EPS foam, 1.5 lbs/ft <sup>3</sup> nominal density.
		Installation:	HercuWall® panels are insert into the bottom track and fastened through the bottom track into the ShearStrip® with one #8 x 3/4 inch (19 mm) screws into each ShearStrip® to locate the panels.
3	ShearStrip®	Manufacturer:	HercuTech Inc.
		Minimum Thickness:	24 gauge (0.022 inches) (0.55 mm) thickness, 2 Inches (51 mm) width.
		Installation:	ShearStrip® are factory installed in HercuWall® panels.
4	Top Track	Manufacturer:	HercuTech Inc.
		Minimum Thickness:	24 gauge (0.022 inches) (0.55 mm) thickness. 2.5 Inches (64 mm) depth.
		Installation:	1 Top Track is installed on interior face, 1 Top Track is installed on exterior face for 2 Top Tracks per panel. Top Tracks are attached with one #8 x 3/4 inch (19 mm) screws into each ShearStrip®.
5	Reinforcing	Type:	Steel
		Specifications:	Minimum Grade 60 per ASTM A615.
		Minimum Size:	#4
		Installation:	Place into the bond beam of the wall and into the prepared rebar hooks (not shown) located in the upper most position of the shear strip. Rebar size and spacing to be in accordance with the Engineering Design for site.
6	Concrete	Type:	3/8 inch (9.5 mm) aggregate, not to exceed 45%.
		Specifications:	Minimum 4,000 psi (27.6 MPa) compressive strength @ 28 days cure per Section 2.2.10 of this report.
		Installation:	Special Inspection and cylinder testing is required.
7	Interior Finish	Type:	Single layer Type X gypsum wall board complying with ASTM C1396
		Thickness:	Minimum 5/8 inches (16 mm).
		Installation:	Single layer on each face. The gypsum is to be anchored into the underlying ShearStrip® at 8 inches (203 mm) on center around the gypsum perimeter and 12 inches (305 mm) on center spacing in the field, with #6 1.25 inch (32 mm) length Type S drywall screws. Joints and screw heads are to be taped and mudded per industry standard.
8	Exterior Sheathing	Type:	Single layer Type X gypsum wall board complying with ASTM C1396 or ASTM C1177.
		Thickness:	Minimum 5/8 inches (16 mm).
		Installation:	Single layer on each face. The gypsum is to be anchored into the underlying ShearStrip® at 8 inches (203 mm) on center around the gypsum perimeter and 12 inches (305 mm) on center spacing in the field, with #6 1.25 inch (32 mm) length Type S drywall screws. Joints and screw heads are to be taped and mudded per industry standard.

Note 1: HercuWall® Series 8 panel assemblies described above, have been evaluated for load-carrying capacity at 100% allowable axial loading as outlined in Tables 2-5 of CER<sub>US</sub>-1003.