

**QAI Design B1123-1b – HercuTech Inc. –ASTM E119  
HercuWall® Series 8 Panel System with CFC Box Beam  
1 Hour Fire-Resistance Rated Load-Bearing Wall Assembly**

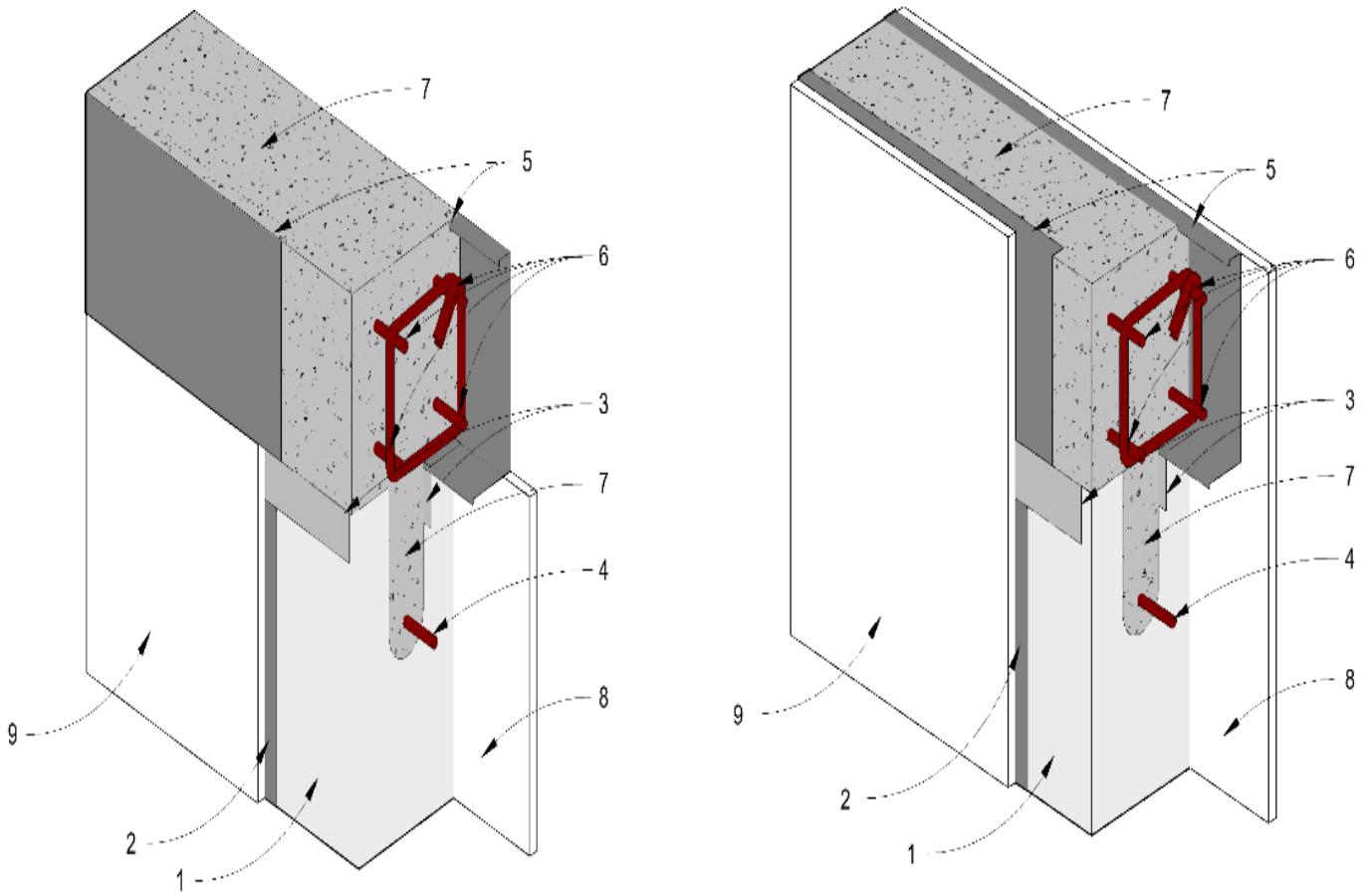

**CFC Box Beam 1 Hour Load-Bearing Fire-Resistance Rating Application Details**

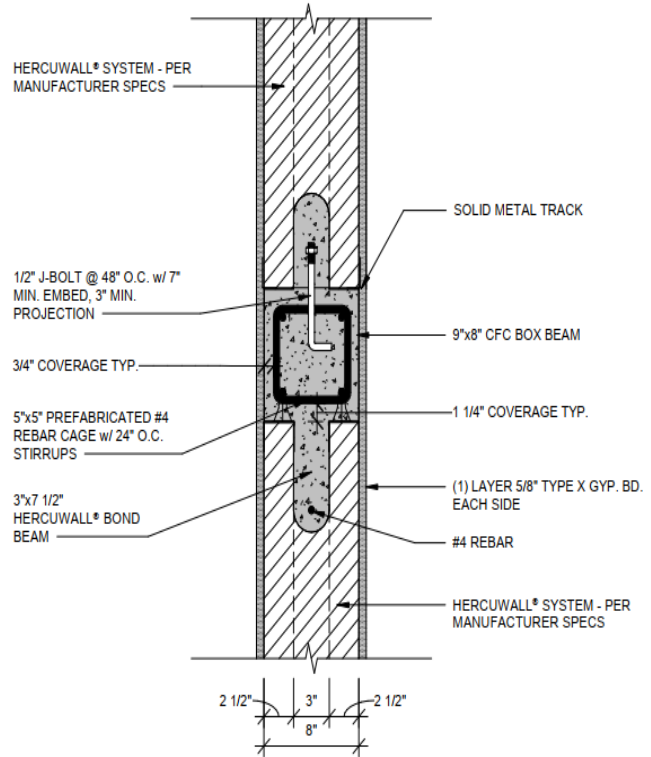
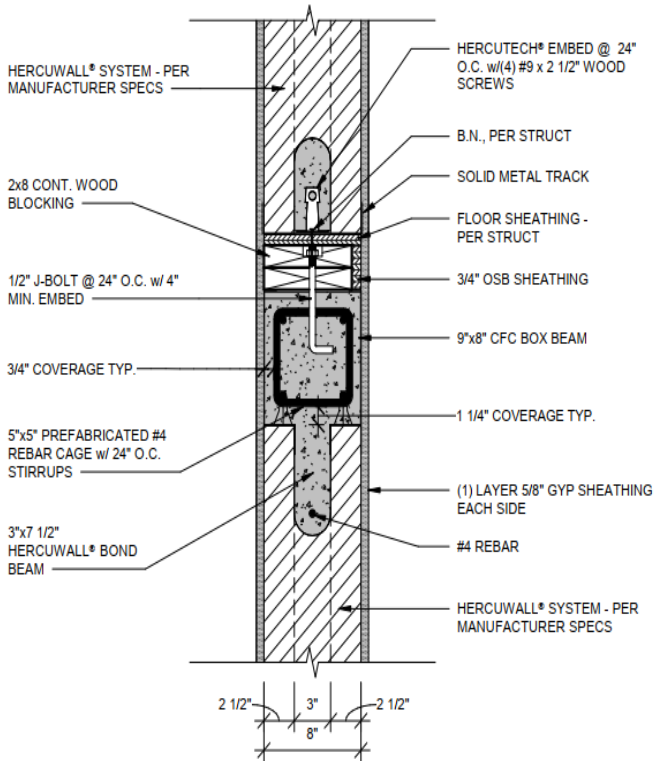

**1-hr Load-Bearing Unbraced CFC Box Beam Wall**

**1-hr Load-Bearing Unbraced CFC Box Beam Wall**

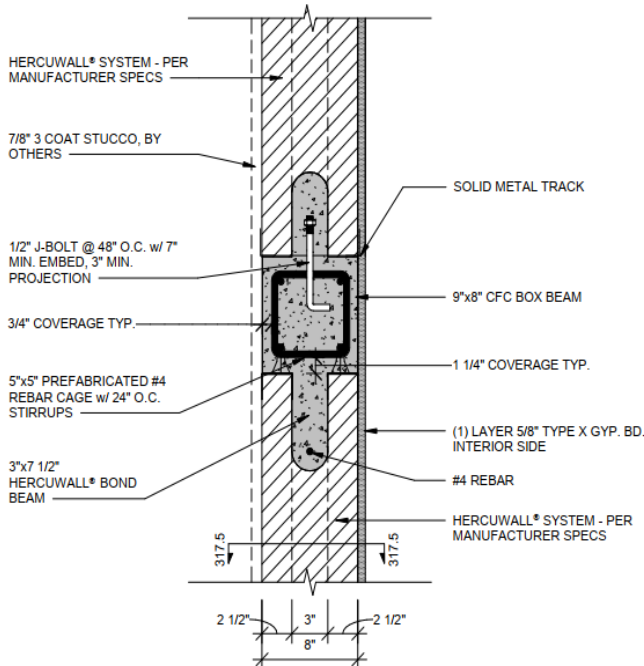

**1-hr Load-Bearing Unbraced CFC Box Beam Wall**

**NOTE:**  
 GAPS BETWEEN TRUSS BLOCKING AND HERCUWALL® FIRE-RESISTANCE RATED ASSEMBLY REQUIRE AN APPROVED 1-HOUR RATED FIRE-RESISTANT JOINT SYSTEM (NOT SHOWN).

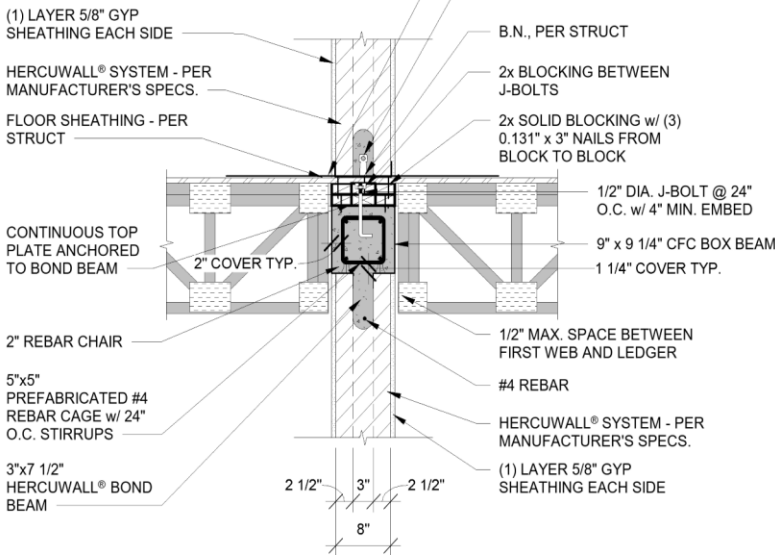

**1-hr Load-Bearing Braced (2 Sides) CFC Box Beam Wall**

**NOTE:**  
 GAPS BETWEEN TRUSS BLOCKING AND HERCUWALL® FIRE-RESISTANCE RATED ASSEMBLY REQUIRE AN APPROVED 1-HOUR RATED FIRE-RESISTANT JOINT SYSTEM (NOT SHOWN).

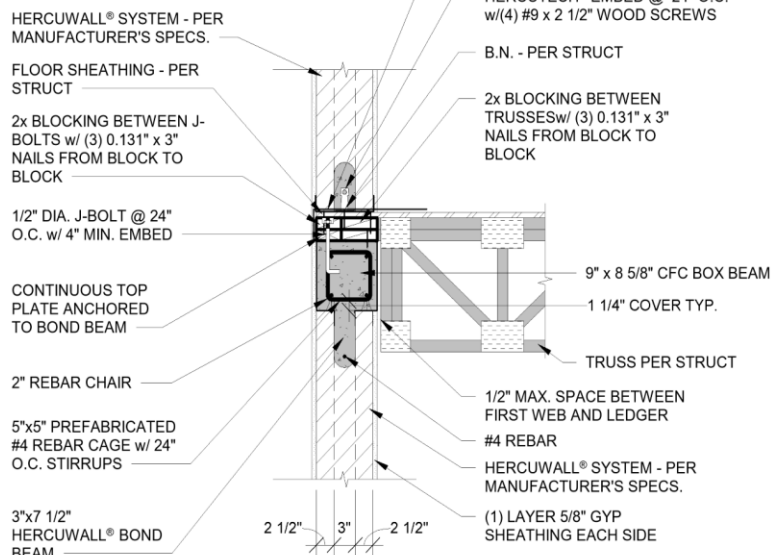

**1-hr Load-Bearing Braced (1 Side) CFC Box Beam Wall**

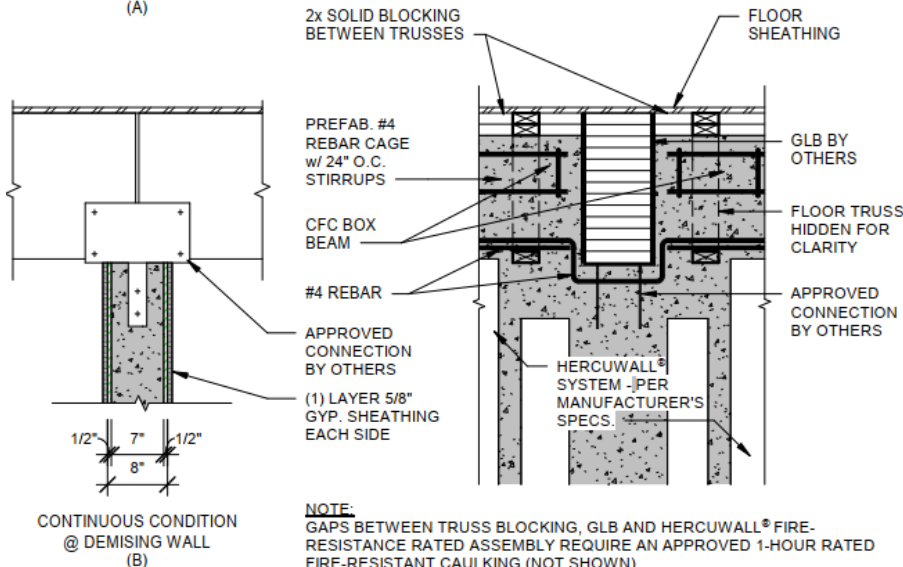
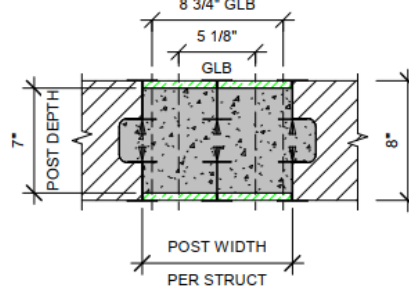
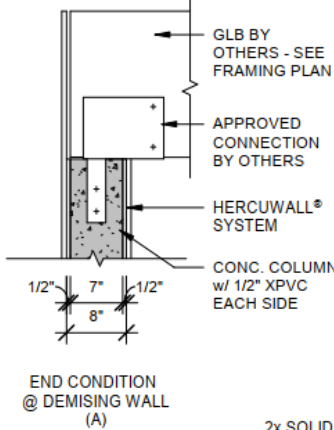

**NOTE:**  
 GAPS BETWEEN TRUSS BLOCKING, GLB AND HERCUWALL® FIRE-RESISTANCE RATED ASSEMBLY REQUIRE AN APPROVED 1-HOUR RATED FIRE-RESISTANT CAULKING (NOT SHOWN).

**1-hr Beam Penetration of Load-Bearing CFC Box Beam Wall**

Item	COMPONENT	DESCRIPTION	
1	HercuWall® Panel	Manufacturer:	HercuTech Inc.
		Approved Types:	Type S, Type SW, Type A products, Type II (1.5 lbs/ft <sup>3</sup> ) nominal density. Solid Shear products, Type IX (2.0 lbs/ft <sup>3</sup> ) nominal density (not shown).
		Installation:	HercuWall® panels are insert into the bottom track and fastened through the bottom track with one #8 x 3/4 inch (19 mm) screw into each ShearStrip® to locate the panels.
2	ShearStrip®	Manufacturer:	HercuTech Inc.
		Minimum Thickness:	24 gauge (0.022 inches) (0.55 mm) thickness, 2 Inches (51 mm) width.
		Installation:	ShearStrip® are factory installed in HercuWall® panels.
3	Top Track	Manufacturer:	HercuTech Inc.
		Minimum Thickness:	24 gauge (0.022 inches) (0.55 mm) thickness. 2.5 Inches (64 mm) depth.
		Installation:	1 Top Track is installed on interior face, 1 Top Track is installed on exterior face for 2 Top Tracks per panel. Top Tracks are attached with one #8 x 3/4 inch (19 mm) screws into each ShearStrip®.
4	Reinforcing	Type:	Steel
		Specifications:	Minimum Grade 60 per ASTM A615.
		Minimum Size:	#4
		Installation:	Place into the bond beam of the wall and into the prepared rebar hooks (not shown) located in the upper most position of the shear strip. Rebar size and spacing to be in accordance with the Engineering Design for site.
5	CFC Box Beam	Manufacturer:	HercuTech Inc.
		Minimum Thickness:	16 gauge (0.060 inches) (1.6 mm),.
		Installation:	Attach the CFC Box Beam to the HercuWall® Top Track using #8 x 3/4 inch (19 mm) self-tapping screws prior to concrete pour. ½ inch (13 mm) diameter J-bolts or #4 rebar dowels are embedded into the CFC Box Beam concrete and protrude into the Base Beam of the above HercuWall® panel for unbraced stacked panel applications. For braced stacked panel applications, embedded J-bolts are utilized to attach a top plate to the CFC Box Beam. J-bolts spacing, embedment and locations details can be found in figures 21-25.
6	Rebar Cage with Stirrups	Manufacturer:	HercuTech
		Size:	Pre-Engineered in size per site specifications.
		Specifications:	Location, size and installation into rebar chairs are to follow Engineering Design.
7	Concrete	Type:	3/8 inch (9.5 mm) aggregate, not to exceed 45%.
		Specifications:	Minimum 4,000 psi (27.6 MPa) compressive strength @ 28 days cure per Section 2.2.10 of this report.
		Installation:	Special Inspection and cylinder testing is required.
8	Interior Finish	Type:	Single layer Type X gypsum wall board complying with ASTM C1396
		Thickness:	Minimum 5/8 inches (16 mm).
		Installation:	Single layer on each face. The gypsum is to be anchored into the underlying ShearStrip® at 8 inches (203 mm) on center around the gypsum perimeter and 12 inches (305 mm) on center spacing in the field, with #6 1.25 inch (32 mm) length Type S drywall screws. Joints and screw heads are to be taped and mudded per industry standard.
9	Exterior Sheathing	Type:	Single layer Type X gypsum wall board complying with ASTM C1396 or ASTM C1177.
		Thickness:	Minimum 5/8 inches (16 mm).
		Installation:	Single layer on each face. The gypsum is to be anchored into the underlying ShearStrip® at 8 inches (203 mm) on center around the gypsum perimeter and 12 inches (305 mm) on center spacing in the field, with #6 1.25 inch (32 mm) length Type S drywall screws. Joints and screw heads are to be taped and mudded per industry standard.

Note 1: HercuWall® Series 8 panel assemblies described above, have been evaluated for load-carrying capacity at 100% allowable loading as outlined in Tables 2-6 of CER<sub>US</sub>-1003.